

TSUBAKI
Integrated Attachment Chain
Special Small Size Attachment Chain

Push It



Grip It

Attach It



Carry It

A Tsubaki integrated attachment chain is the

Need

I want to reduce the time and trouble of mounting attachments!

Push It

Solution

Integrate attachments that are absolutely necessary for your production line with the chain. This nicely solves problems with cost, trouble, and waste.

Point

The attachments and chain are integrated, so there is no trouble or costs related to attachment mounting.

Need

I want to smoothly replace my special foreign-made chain!

Grip It

Solution

Introduce an integrated Gripper chain. Spring film grippers in customized strengths and shapes available.

Point

Tsubaki can handle quick changes to specifications for genuine parts that take time to procure. We also offer complete after-sales service after you receive your chain.

Need

My chain isn't durable enough. I want a longer life chain!

Push It

Solution

Use a Tsubaki integrated attachment chain for longer chain life.

Point

You can reduce your number of chain replacements by using a Tsubaki integrated attachment chain. This will also greatly decrease the trouble and costs related to replacement.

Hint

What does "integrated" mean?

"Integrated" means a chain with attachments (jigs) included in with the chain beforehand (instead of attaching them later with bolts).

perfect solution to all your conveying needs

Need

I want to reduce my costs for the special blocks I use and try to reduce the mounting time!



Carry It

Solution

Add an integrated attachment chain solution to eliminate the block and reduce slat attachment time.

Point

With just a little cleverness and originality, we were able to reduce the customer's costs and labor. The customer also used Tsubaki Lambda Chain for less equipment downtime.

Need

I want to use the best chain for manufacturing and conveying my product!



Push It

Solution

Increase chain life and stabilize production.

Point

We developed an original chain with attachments that was ideal for the product and shipped it as one integrated attachment chain. Not only did this lower costs for the customer, but it also increased the chain life.

Need

We currently make our attachments ourselves, but we want to cut our costs and trouble!



Carry It

Solution

Reduce costs by using integrated attachment chain.

Point

We eliminated the cost and trouble for the customer to make the attachments themselves. We also keep the die for them so that we can handle any additional attachment orders and replacements quickly.

Successful Applications

Tsubaki meets the needs of customers in every industry and field!

Understand the benefits of using integrated attachment chain at a glance!

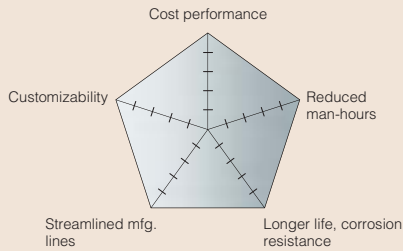

We have established five categories of benefits for our customers graded in five steps. One quick glance at the radar chart and customers can see what will resolve their particular problem and what benefits their choice will bring. Use the chart when considering the right integrated attachment chain for you.

Cost Performance

We can propose a chain that will lower overall costs – initial costs, costs associated with developing and manufacturing an attachment chain, costs when replacing your chain or ordering additional chains, etc.

Reduced Man-hours

We can propose a chain that will reduce worker costs and effort – time spent mounting jigs to attachments, chain replacement work, downtime for maintenance, etc.

Longer Life, Corrosion Resistance

We can propose a chain that matches your production process and environment – longer life with Tsubaki Lambda® Chain, corrosion resistance for use in special environments, etc.

Streamlined Manufacturing Lines

We can propose an integrated attachment chain that streamlines work conveyance on your manufacturing lines – more stable conveyance, optimized attachment shape, more compact equipment.

Customizability

We can provide customized solutions (from development to production) with original attachment chains to replace your existing chain. Let Tsubaki propose a customized solution that meets your needs.

Steelmaking

Reduce parts and use a smarter chain.

We proposed a chain with an integrated attachment to replace their specifications calling for a chain with jigs attached by bolts. This allowed the user to switch from unstable single-sided conveyance to stable dual sided conveyance.

Customer feedback

The chain we were purchasing on a regular basis was expensive, so integrated attachment chain allowed us to reduce costs.

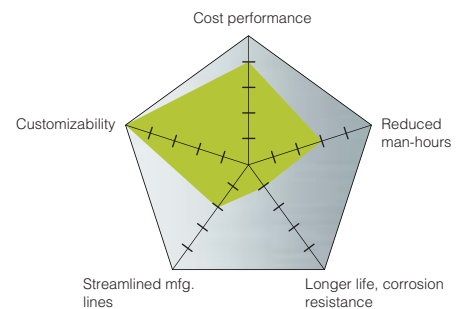

BEFORE

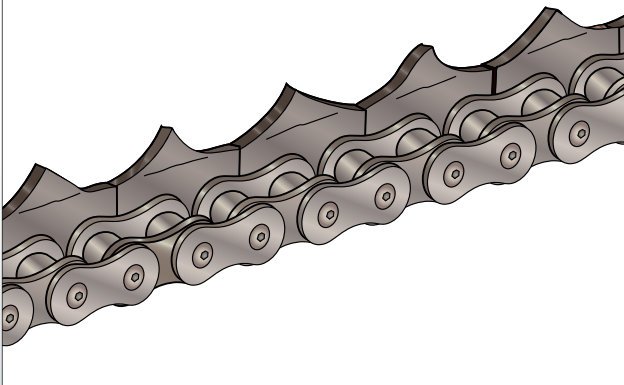

AFTER

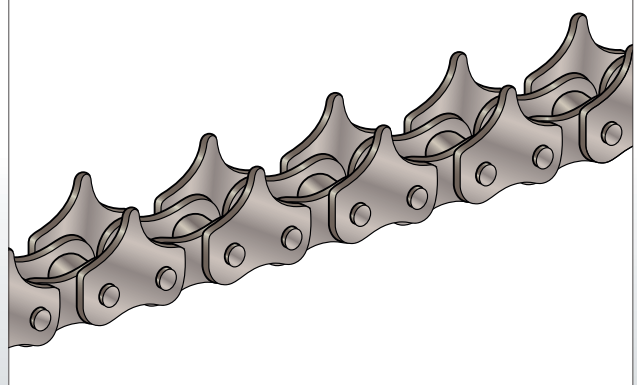

Stationery

Using integrated attachment chain made plate processing and mounting unnecessary.

Integrating the chain and jigs reduced the time needed for plate processing, mounting, and design. Further, integrated attachment chain allowed them to source from one supplier, make their equipment more compact, and increase their positioning precision.

Customer feedback

We were able to eliminate the mounting work and outsourced processing work, which helped us make our equipment more compact.

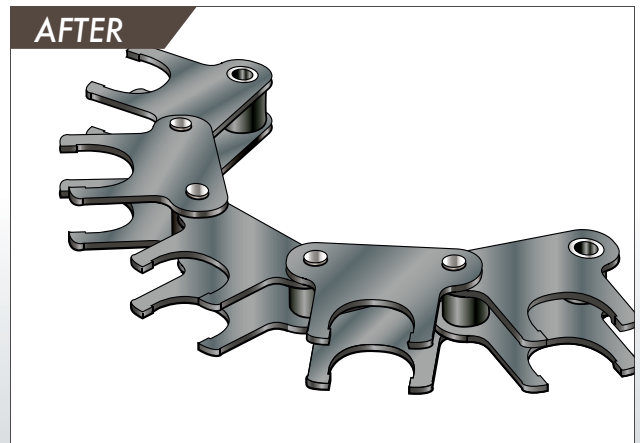
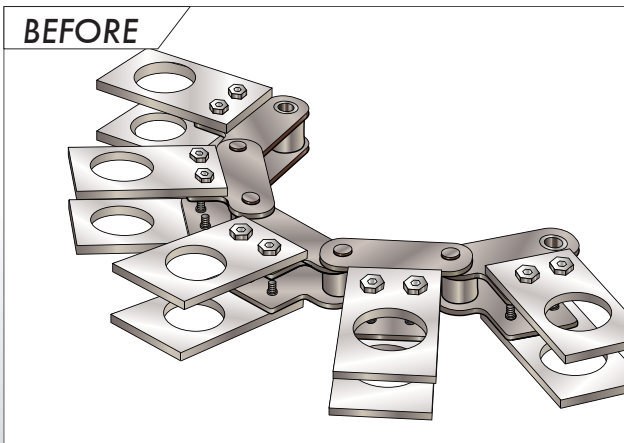
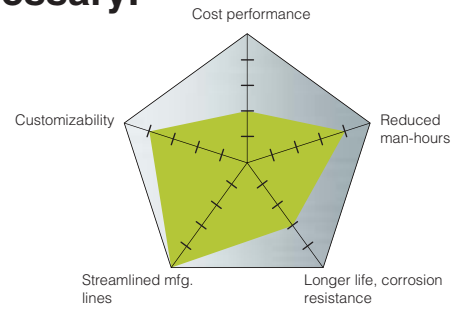

Confectionery

Uses alternating pitches so that the chain can be used with standard sprockets.

We were able to increase the customer's work efficiency by delivering them a chain with bars included. Normally they used a triple pitch design, but they needed to manufacture a custom sprocket. With the switch to alternating pitches they were able to use standard sprockets.

Customer feedback

Alternating pitches was a good idea. It helped us reduce costs because we could use standard items.

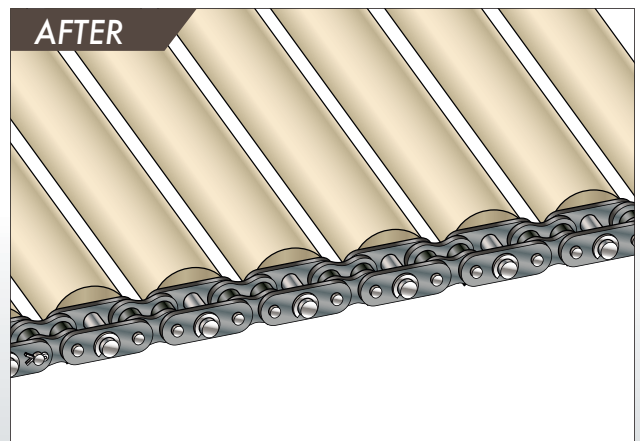
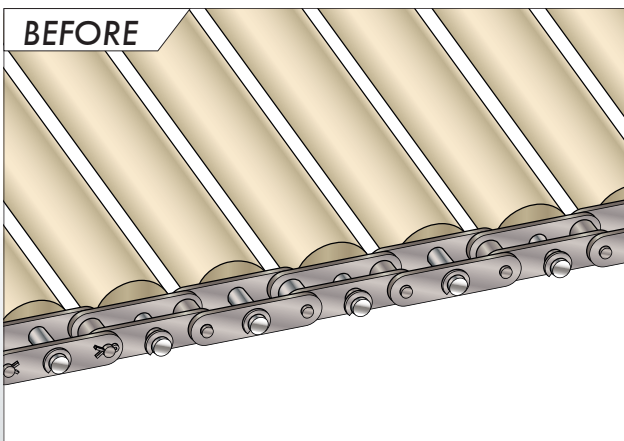
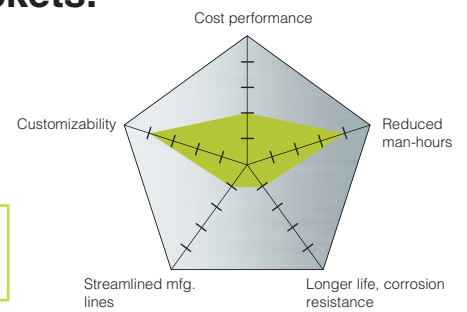

Conveyors

Major savings with integrated attachments.

The existing attachment (machined) was expensive and deliveries were irregular. By using a UM attachment bent inward from Tsubaki, the customer was able to reduce costs and shorten delivery times. And by using Lambda Chain they were further able to reduce running costs.

Customer feedback

Not only did we reduce costs and shorten delivery times, but we were also able to extend the life of the equipment and increase productivity.

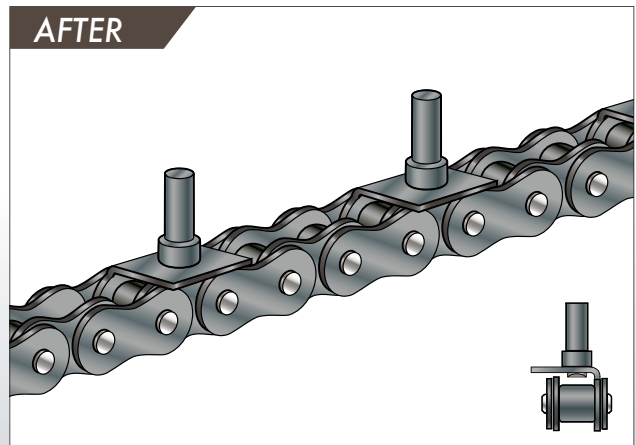
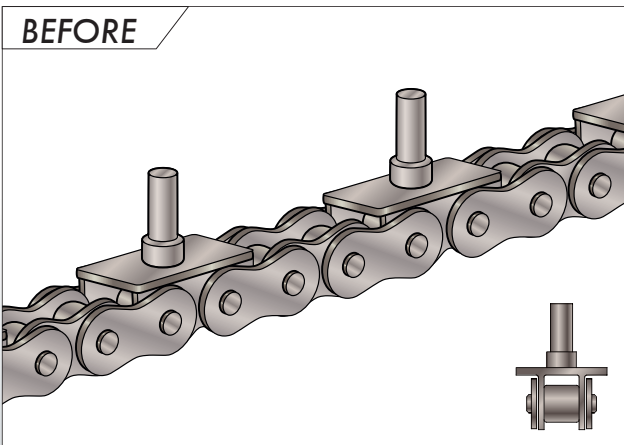
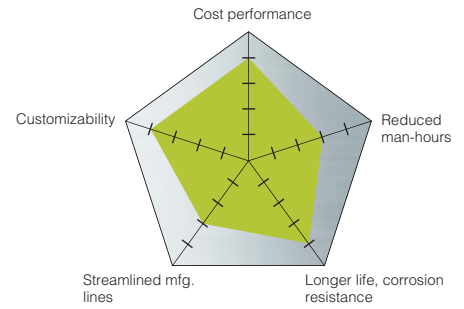

Food

Integrating attachments reduces the risk of foreign matter getting into food.

By integrating standard and special attachments with the chain, we reduced the risk of foreign matter from welding cracks getting into food. The chain could also be installed right after delivery, which meant shorter downtime for the customer.

Customer feedback

In the food industry, foreign matter in food could be lethal, so with Tsubaki chains we knew we were safe.

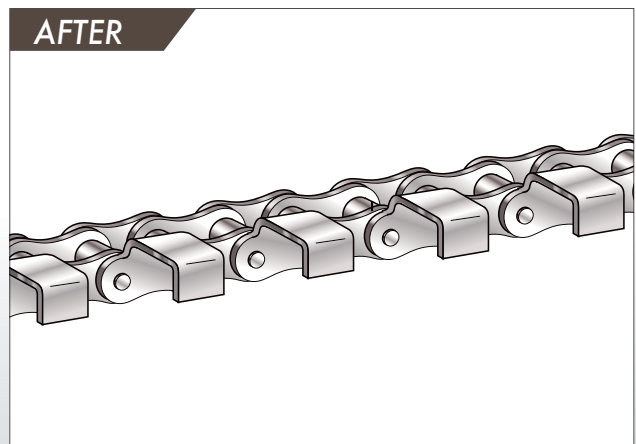
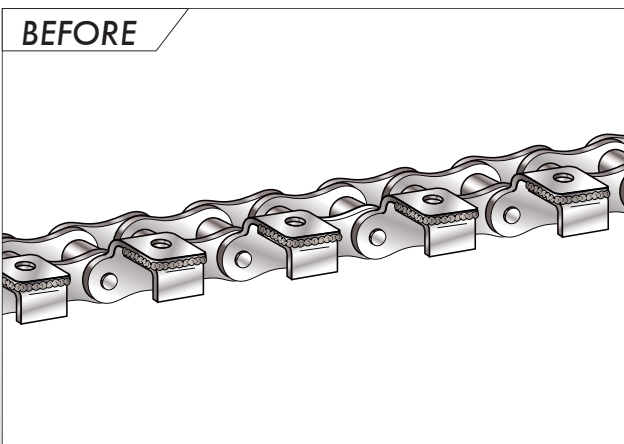
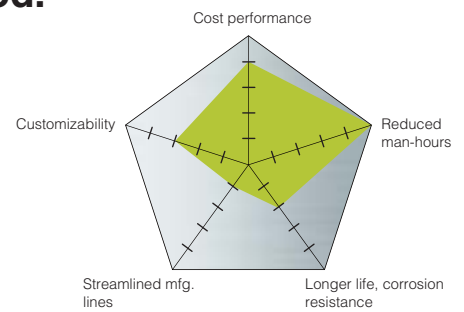

Confectionery

Integrated attachments reduce replacement time.

Integrated attachments greatly reduce the time needed to replace the chain. They also mean fewer parts, so customers can get everything from one source and reduce overall costs.

Customer feedback

We eliminated work that we always thought was necessary and increased our equipment operating rate.

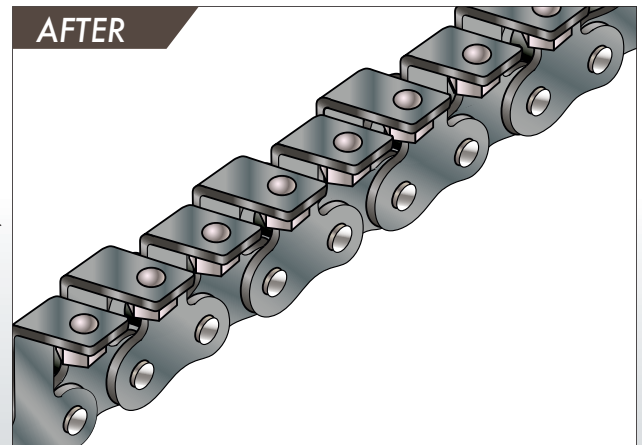
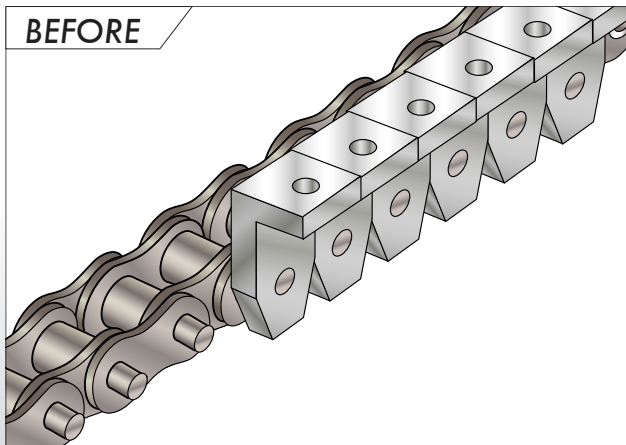
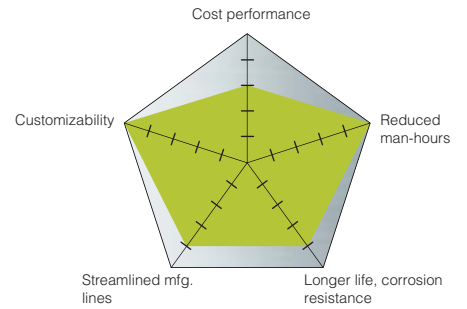

Heat Treatment Furnaces

Lower costs through simplified jigs and attachments.

We reviewed the customer's jig and attachment shapes and proposed a standard chain with a simple jig shape. This reduced their costs and delivery times and contributed to higher quality and more stability.

Customer feedback

We looked into fancy specifications to match the items we were conveying, but Tsubaki had the idea to simplify the shape. This allowed us to shorten our jig manufacturing and attachment work.

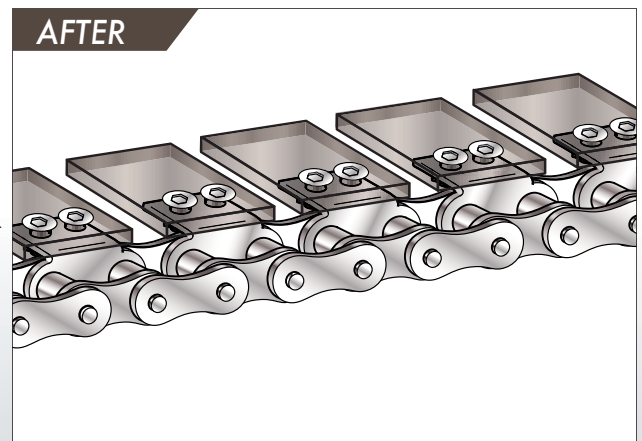
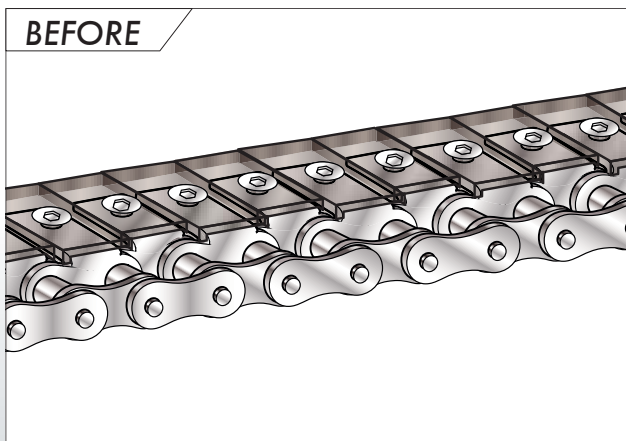
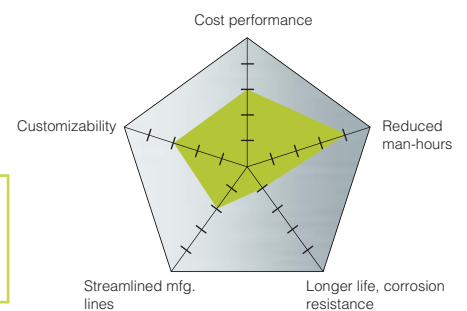

Papermaking

Tsubaki can provide chains and special jigs for foreign-made equipment.

Tsubaki can manufacture an integrated attachment chain that includes both the base chain and special jigs that had to be ordered from a foreign equipment manufacturer.

Customer feedback

We were able to reduce delivery times and costs compared to sourcing from the foreign equipment manufacturer.

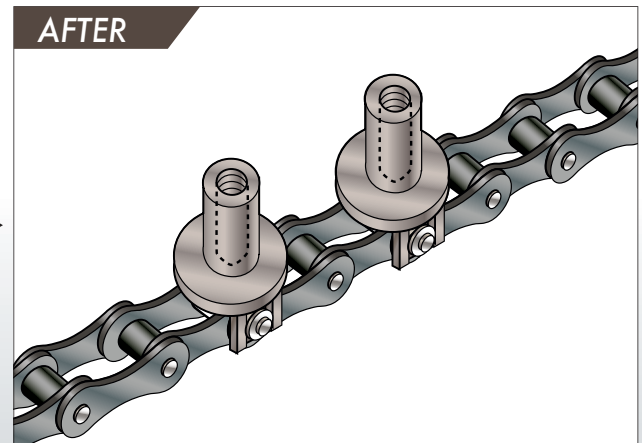
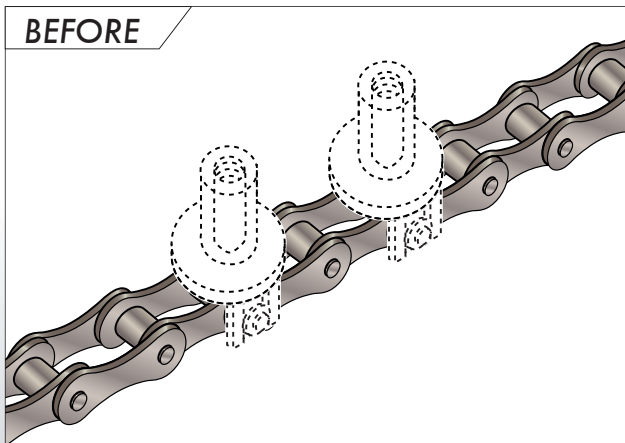
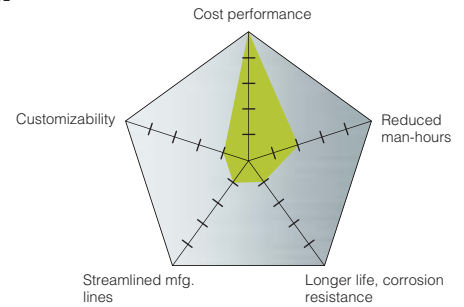

Inspection Equipment

Reduce costs and man-hours by switching the chain's construction.

Tsubaki proposed switching from bolting slats to the attachments to a chain with the slats integrated. This saved the customer labor as well as money, as they no longer needed the expensive aluminum blocks that caused them trouble.

Customer feedback

By just inserting one plate, Tsubaki was able to achieve the original no backbend function.

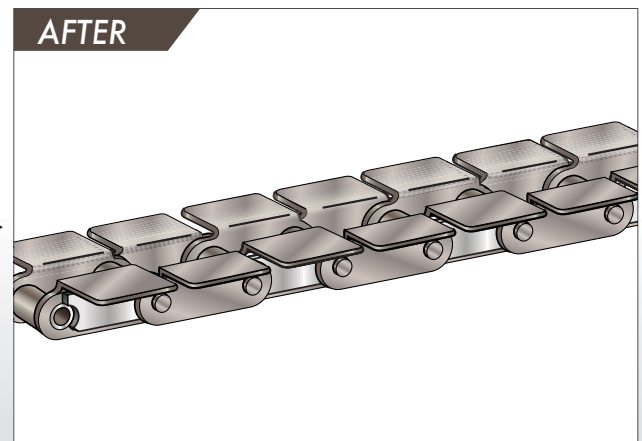
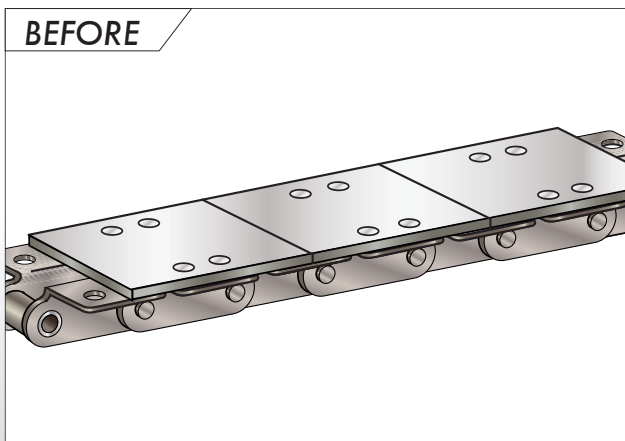
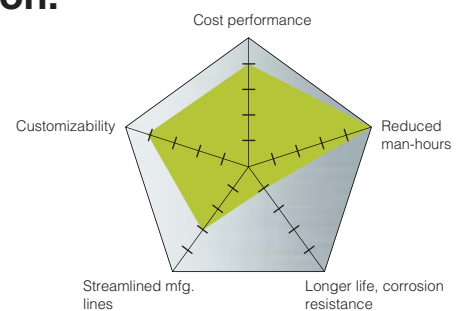

Confectionery

Reduce operating loss by changing how you receive your chain.

Tsubaki proposed switching from a foreign-made chain with the plates and bars welded on separately to an integrated chain specification. The chain ran smoothly after they received it, and it was cheaper than sourcing from an overseas supplier.

Customer feedback

We didn't know that Tsubaki could supply us with a custom chain with the same shape as our original chain.

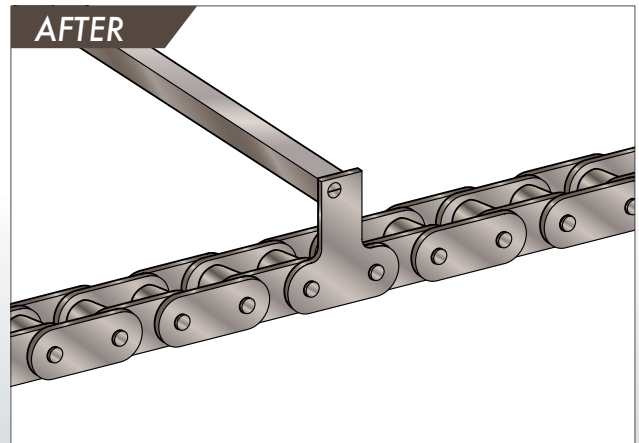
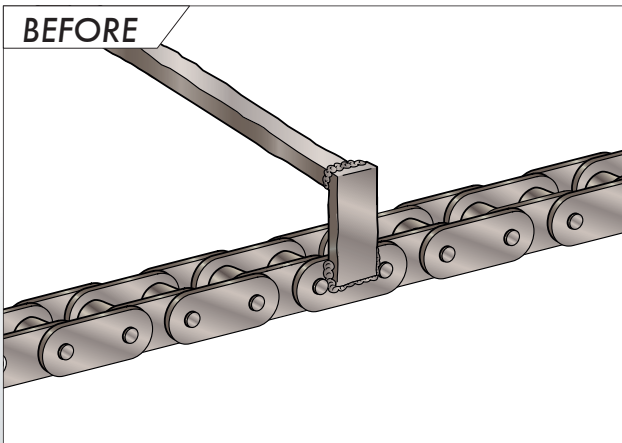
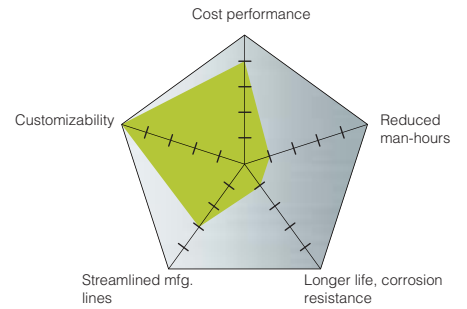

Beverages

Switching jig materials for a longer chain life.

We proposed changing the material of the slats on the original chain in order to further extend their corrosion resistance and life. Tsubaki also changed the base material of the chain for longer life too. By switching to Tsubaki, the customer was able to decrease delivery times and costs.

Customer feedback

The Tsubaki chain solved all our problems with corrosion, product life, and delivery.

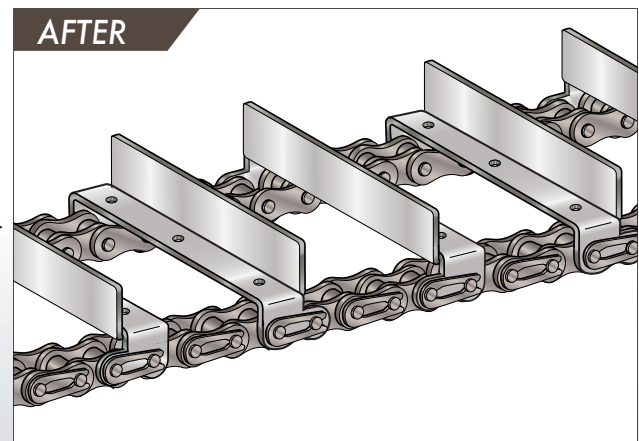
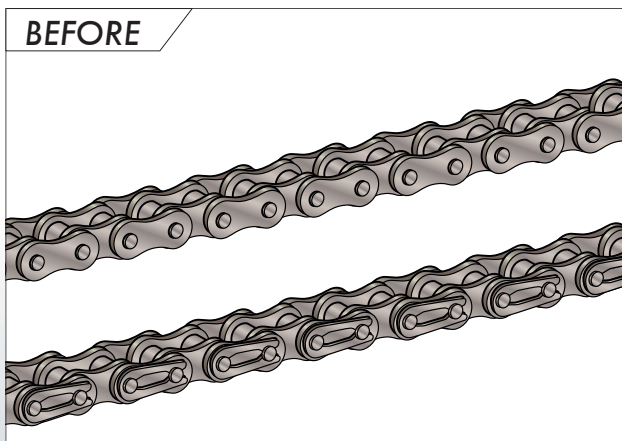
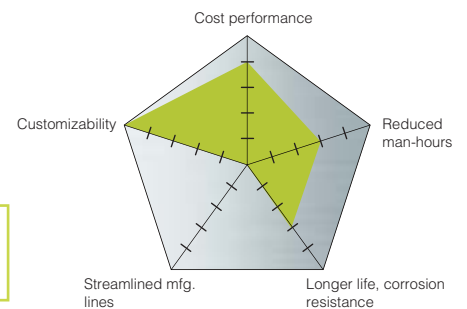

Steelmaking

Eliminate on-site welding and slat attachment, and extend product life.

The customer feared link plate strength would drop from block welding, so we recommended a Tsubaki L-shaped attachment. Their problems with breakage disappeared, and they enjoyed longer chain life.

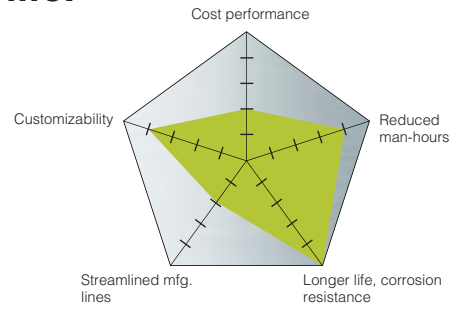

Customer feedback We didn't realize that welding shortened a chain's life. We're happy with our Tsubaki chain.

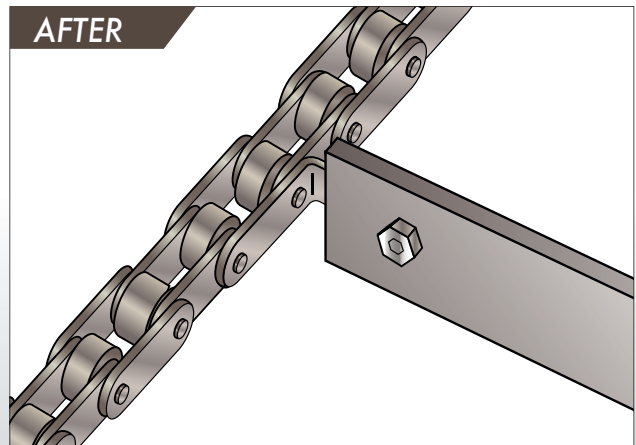
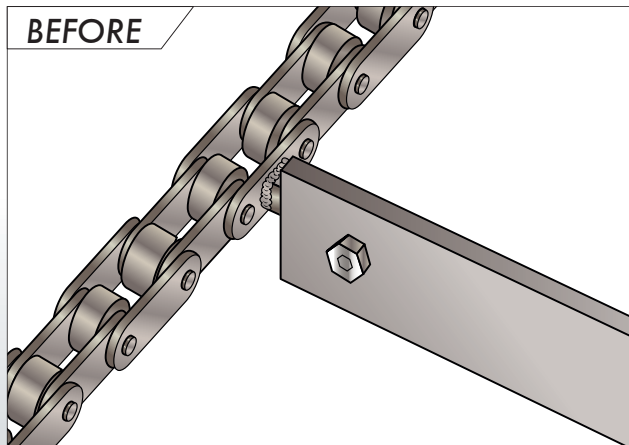

Automotive Parts

Reduce attachment labor time with a chain integrated with jigs.

We proposed an integrated attachment chain with integrated jigs, which saved the customer the trouble of attaching the bars and greatly reduced their labor time while providing longer product life.

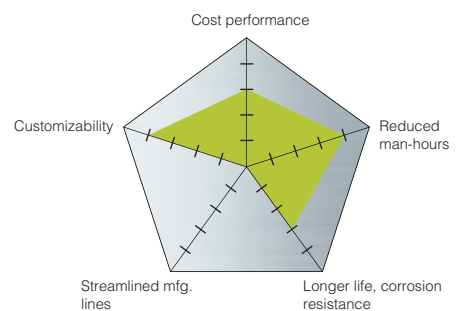

Customer feedback We were able to install the chain in our equipment right after we got it, which also helped us cut down on equipment downtime.

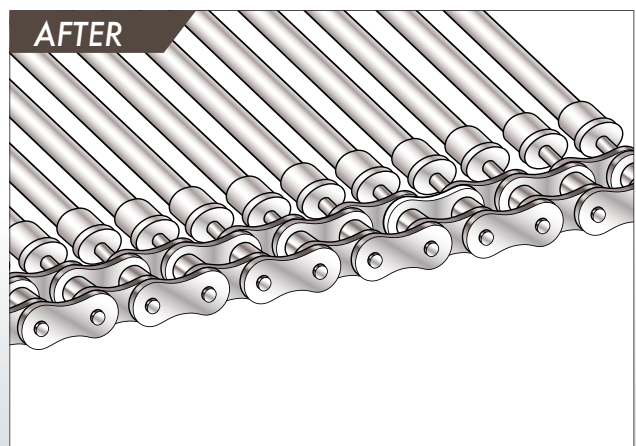
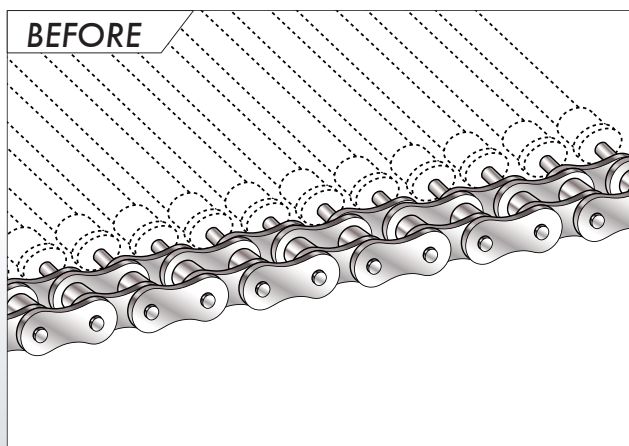

Food Equipment

Switching from manufacturing and assembly to an integrated attachment chain reduced labor and personnel costs.

Tsubaki proposed an integrated attachment chain that included a specially shaped attachment, which reduced the chain manufacturing costs as well as the purchasing costs for connecting links. By eliminating unnecessary chain cutting, the chain helped increase the quality and stability of their equipment.

Customer feedback

We were able to reduce labor time and additional processing on-site. We could also install the chain on the equipment right after we got it.

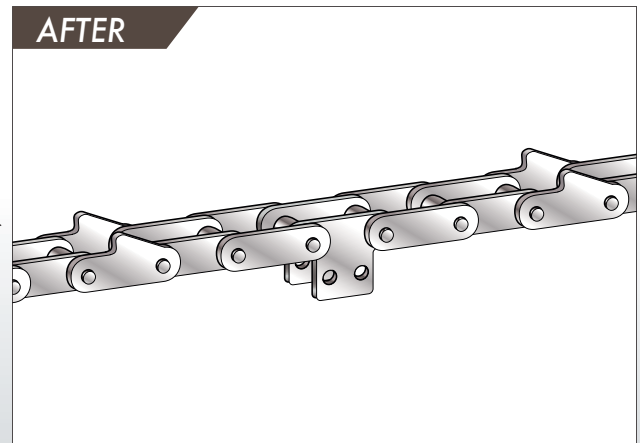
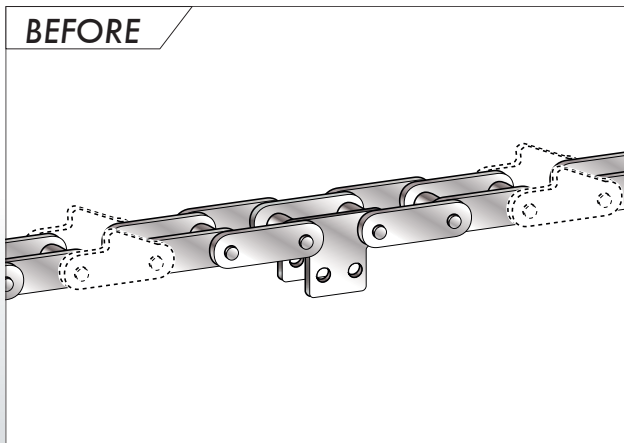
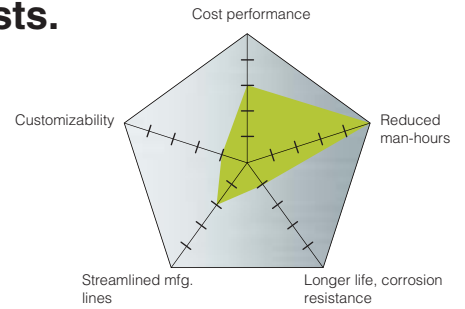

Housing Construction

Eliminating bolts and nuts to save time and money.

We eliminated the need for the customer to attach bolts and nuts one at a time to the attachment on-site, which reduced the time needed for chain processing as well as the attendant labor costs.

Customer feedback

We were able to greatly reduce the time needed for on-site attachment. We plan to use integrated attachment chains on other lines as well.

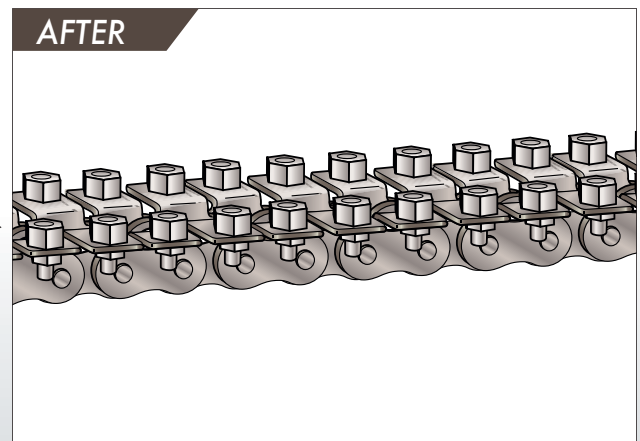
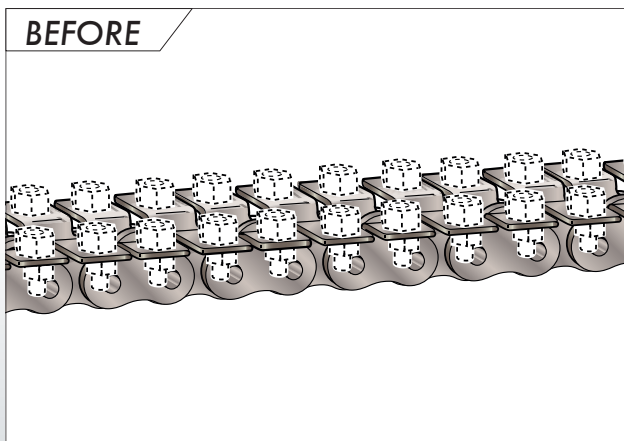
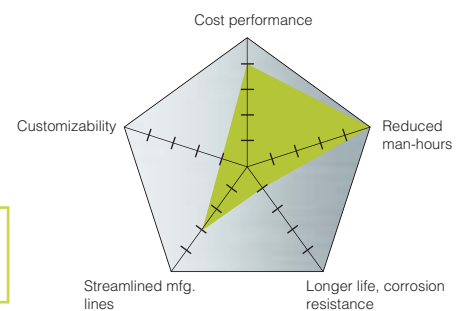

Food

Lower overall costs thanks to special attachments.

We proposed using a special attachment chain in place of a standard chain with buckets and bars welded on. This allowed the buckets and bars to be attached easily, with or without welding needed. The new chain also contributed to longer chain life.

Customer feedback

I didn't need to weld anymore, so installing the chain was easy. It really helped me out to buy the bar and chain as a set.

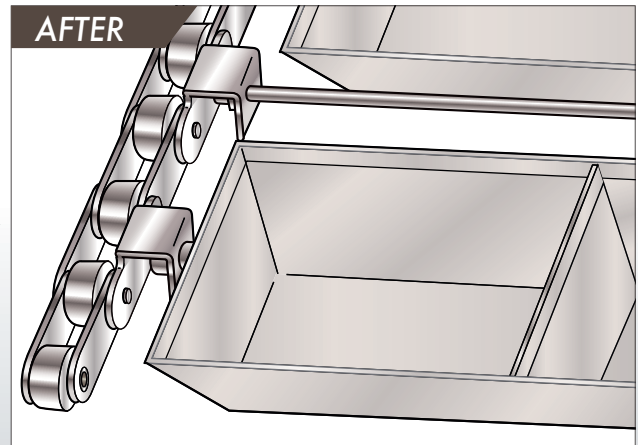
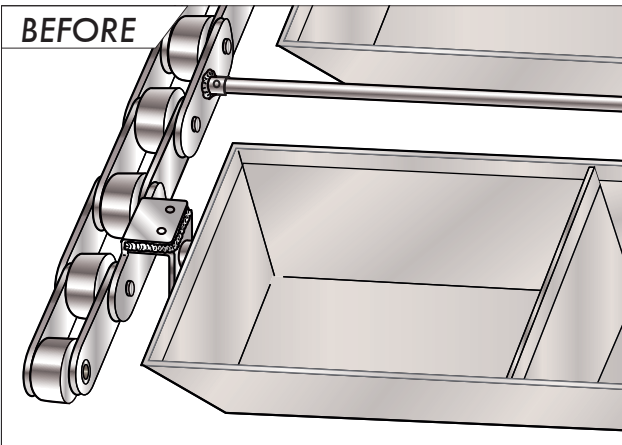
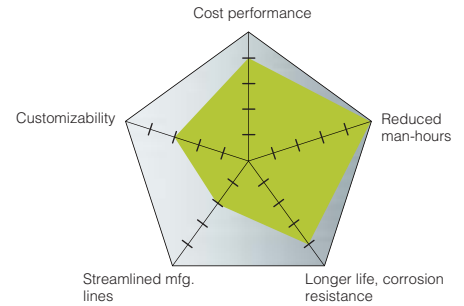

Noodle Making

Integrated attachments mean fewer part orders and less assembly time.

We proposed integrating the special parts that the customer outsourced manufacturing of with the chain. The result was fewer part orders and less assembly time, and once delivered the chain could be quickly installed in the machine.

Customer feedback

Not only did we reduce our special part orders and assembly, but we halved the time needed for managing stock items.

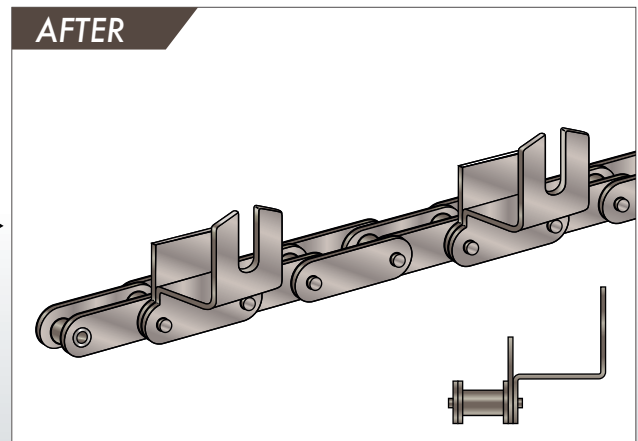
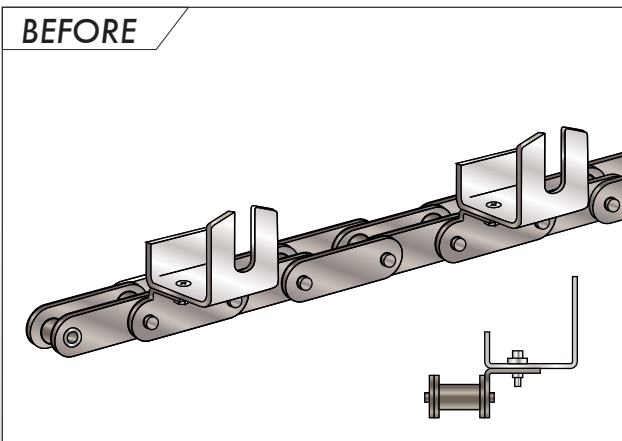
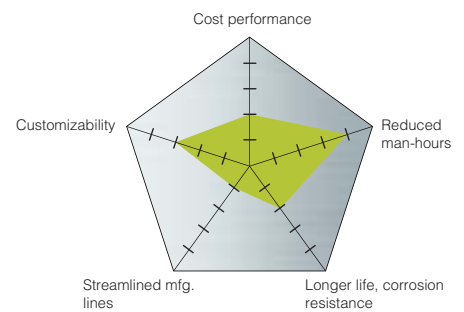

Packaging

Made-to-order blocks were replaced with special attachments.

In the past, the customer attached special made-to-order blocks to extended pins, and the slats were attached with bolts. The blocks were machined and required exacting precision, which meant high procurement costs. We proposed a special attachment that would function as a block and would be integrated with the chain.

Customer feedback

Using the special attachment meant that we were able to keep procurement costs down for the entire conveyor.

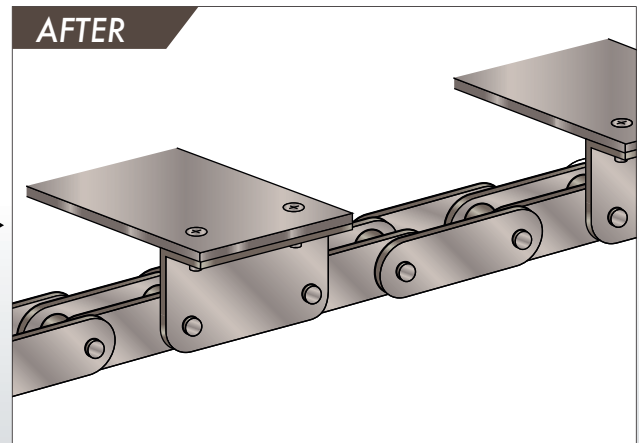
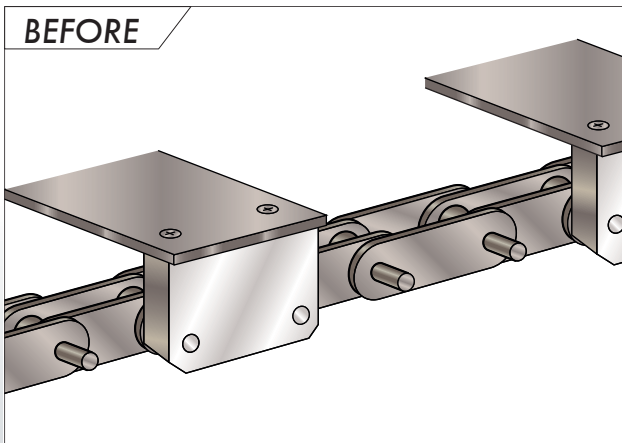
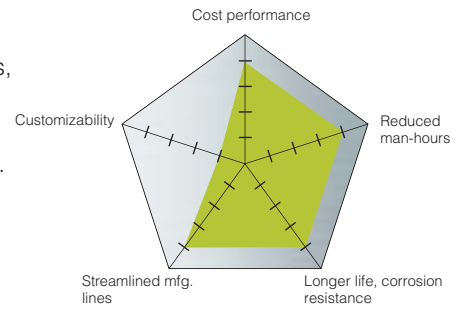

Automotive Parts

Increased durability by proposing a special extended shoulder pin.

When the customer additionally machined the extended pins and mounted attachments to them, the pins would deform and break, reducing the life of the chain. They asked us to offer improvements, so we proposed a special extended shoulder pin.

Customer feedback

The chains were more durable, and we were satisfied with not having to do any additional machining to the chain.

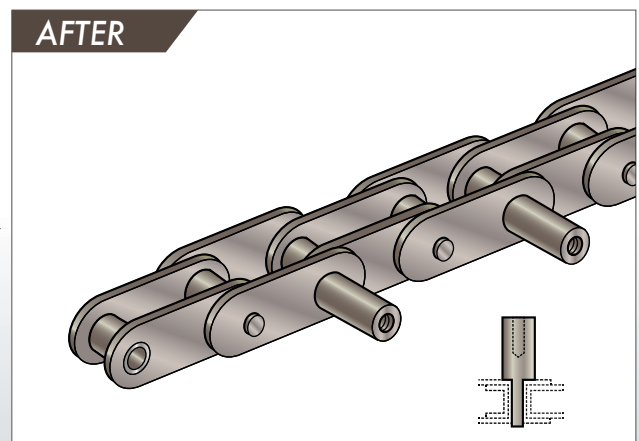
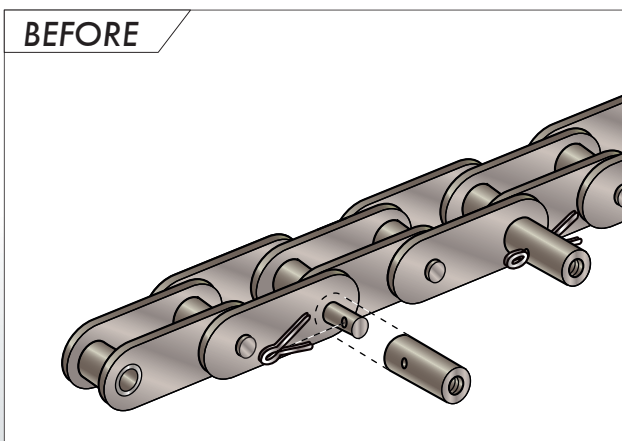
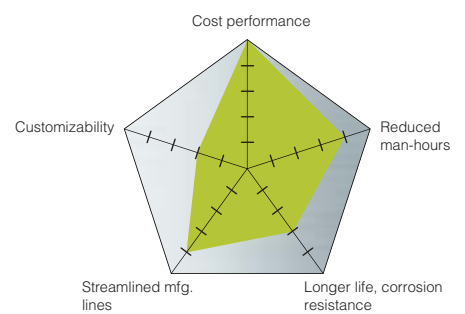

Food

Reduced costs by including jigs on special attachments.

The customer machined jigs to mount scrapers, but there were a lot of jigs so the manufacturing and mounting costs were high. They asked us if there was a better way, so we proposed a special attachment that would include the jigs.

Customer feedback

I didn't know it was possible to make attachments in this shape. We were able to reduce costs by using integrated attachment chain.

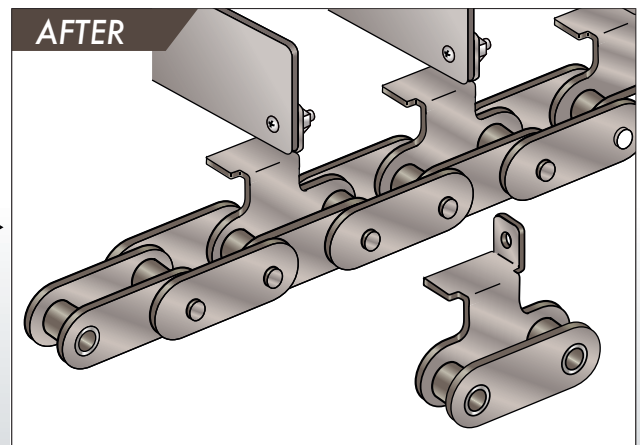
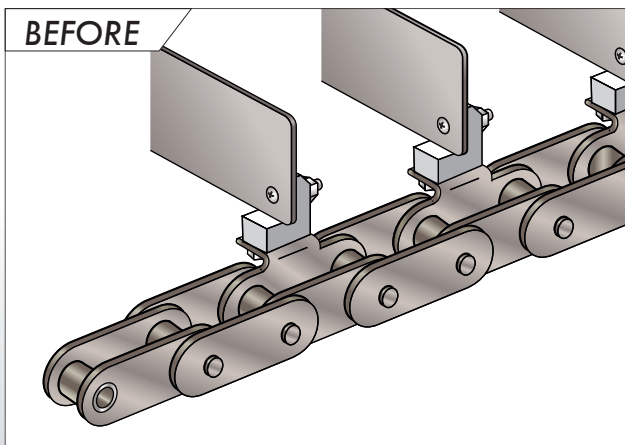
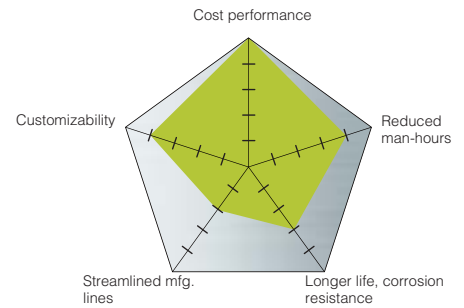

Packaging

Simplified the plastic blocks using special attachments.

The customer mounted a gate-shaped plastic block onto a standard attachment chain, but manufacturing the plastic blocks took a lot of time and money. We simplified the shape of the plastic blocks using a special attachment to save the customer time and money.

Customer feedback

By changing our way of thinking, we saw how we could save money. We also reduced the time it took to get the plastic blocks.

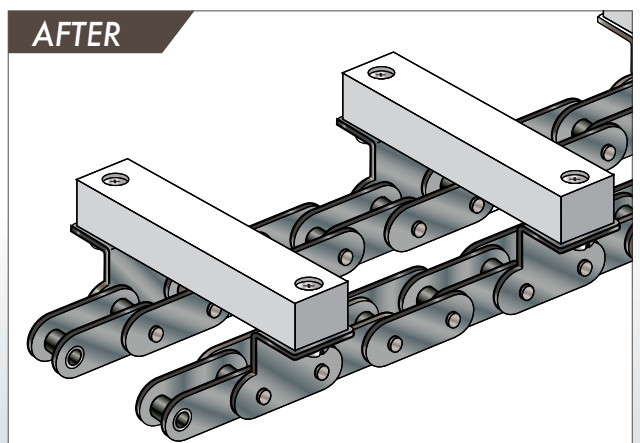
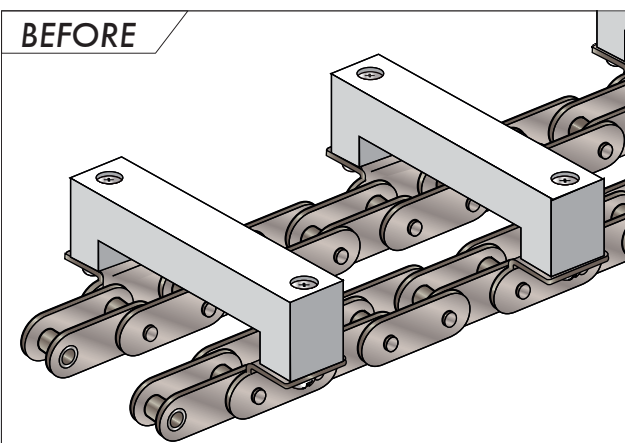
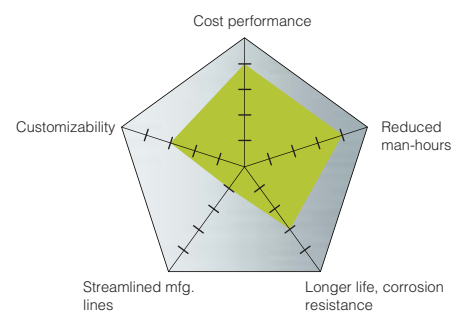

Metal Working

Reduced maintenance costs thanks to integrated thinking.

The customer mounted slats to the chain while adjusting the equipment, but work efficiency was low and it took a lot of time. We recommended using press nuts, which reduced the time it took to mount the slats and the time it took to procure the slats and other parts.

Customer feedback

We replace the slats regularly, so integrated attachment chains helped us reduce our work time.

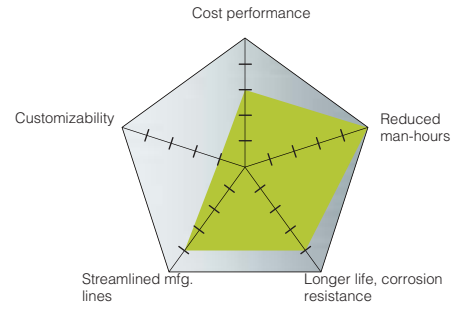

BEFORE

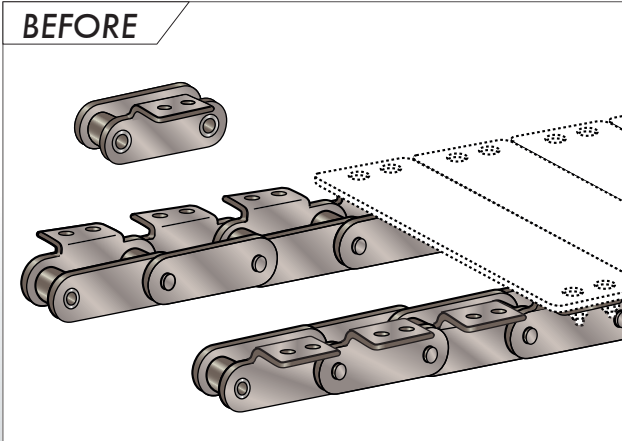

AFTER

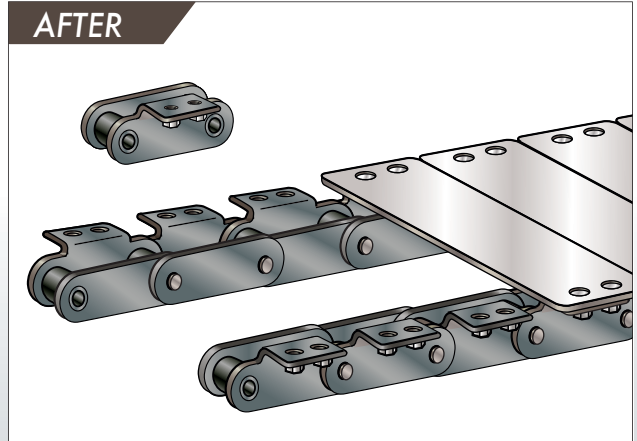



Examples of Special Attachments for Tsubaki Lambda® Chain

1. Tsubaki has a long history of providing not only standard attachments but integrated attachments to meet each customer's application, equipment, environment, or work shape needs.
2. Our wide line-up of integrated attachments is used by our customers as their de facto attachments.
3. Contact Tsubaki with information on your application, equipment, environment, and work shape. We can manufacture a Lambda Chain with integrated attachments just for you.

Chain with holes for press nuts and screws

Press nuts are press fit into chain attachments, or screw holes are directly tapped into the plates. Slats and jigs can be directly attached with just screws and bolts for much better workability.

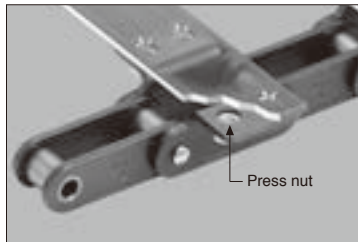

Chain with press nuts on K2 attachments

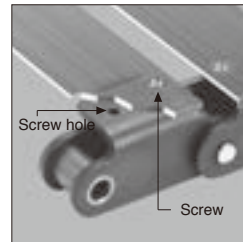

Chain with screw holes on A2 attachments bent inward

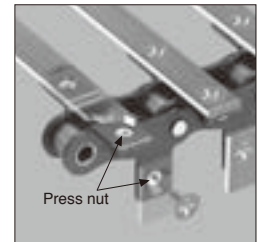

Chain with press nuts on K1 and SA attachments

Free Flow Chain

A Free Flow Chain that uses a Tsubaki Lambda Chain as the base chain. The base chain does not need to be lubricated, but the steel top rollers or outboard rollers do. (Plastic top rollers and outboard rollers do not need to be lubricated.)



Double Plus® Chain

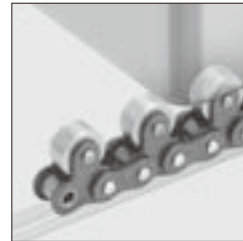

Top Roller Chain

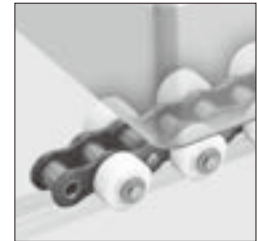

Outboard Roller Chain

Top Chain for direct conveyance

This chain is for directly conveying various machine parts or containers such as bottles, cans, and paper packs. The base chain is Lambda Chain.



TS Series Top Chain

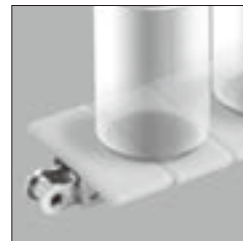

TN Series Top Chain

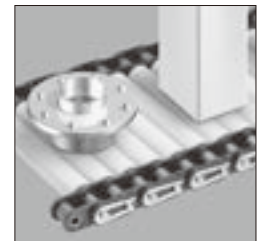

RT Series Roller Table

Special attachment chain for direct conveyance

This Lambda Chain features specially shaped attachments that match the shape of round bars, pipes, small boxes, and other work.

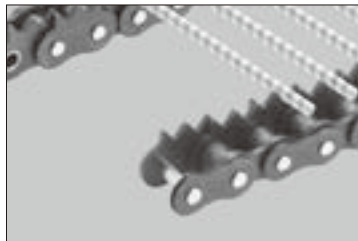

Chain with triangular attachments for round bars

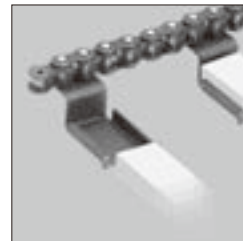

Chain with bracket-shaped attachments for small boxes



Chain with V-shaped attachments for pipes

Chain with bracket-shaped attachments for direct conveyance

This chain is for directly conveying pallets, cardboard boxes, plastic boxes, and so on. Tsubaki can also provide stainless steel attachments, bracket-shaped attachments, rubber pad attachments, and others to meet your application needs.

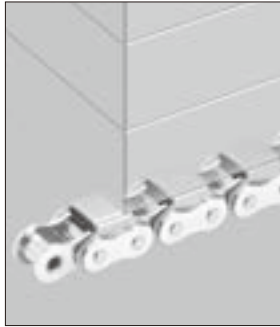

Chain with bracket-shaped attachments (stainless steel)

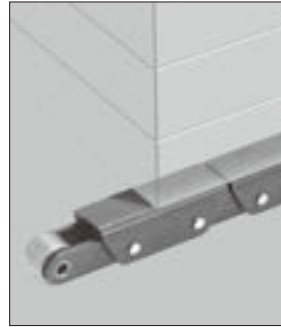

Double pitch chain with bracket shaped attachments



Double strand chain with rubber pad attachments

Extended pin chain

Chain with extended pins, threaded extended pins, and extended pins with clips for mounting various attachments. (For attaching nuts, inserting pipes, or affixing with clips.)

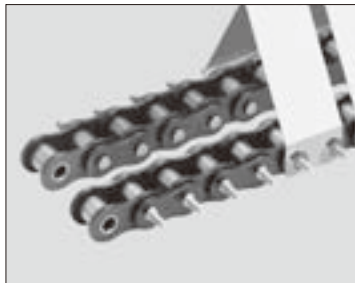

Threaded extended pin chain

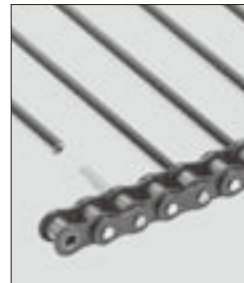

Extended pin chain



Extended pin chain with clips

Chains for bar, slat, and net conveyors

This chain features holes in special attachments for mounting slats, shoulder bars, angular bars, round bars, and other uniquely shaped jigs.

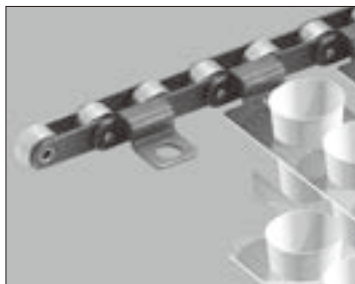

Slat conveyor chain with holes (chain center and slats are at the same height)



Step bar chain (ends fit into center hole)



Square bar chain



Net conveyor hollow pin chain with guide rollers



Bar attachment bushed chain

Chains that convey by gripping work

These chains form two conveyors that grip an object between them using the stay pins of the chain, or a bent-over open-box-shaped attachment.

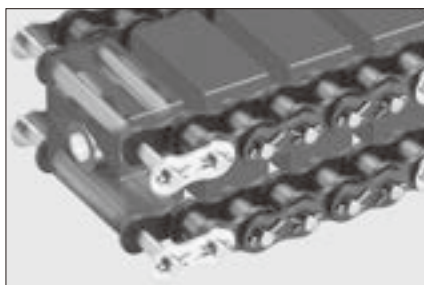

Stay pin chain (with blocks attached to the stay pins)



Chain with inwardly bent attachments

Integrated Attachment Chain

	Specifications	Explanation	Page No.
Quick Delivery	Special hole diameter attachment (A & K attachments)	Chain incorporating attachments with the most typical special hole diameters (equivalent to JIS-2 class bolt holes) from amongst our numerous attachments	18
	Press nut attachment (A-NM & K-NM attachments)	Chain with nuts added on the attachments. Slats can attach easily.	19, 20
	Special extended pin (EPL)	Chain with special extended pins with common parts so that they can be manufactured for shorter delivery times	21, 22
Design Stock	Ground surface attachment (PG)	The rollers are ground, and the upper surfaces of the attachments are ground as well.	23
	RS® large size chain with attachment	RS180 or larger size RS chain with attachments.	24
	Double pitch deep link chain (DL attachment)	Height of the link plates (dimension H1) is higher than the top of the roller on a double pitch base chain. Direct conveyance is possible, even with R rollers.	25
	Inwardly bent attachment (UM attachment)	Items can be directly conveyed on or between the inwardly bent attachments. The upper face of the attachment has been chamfered to minimize scratching on conveyed items.	25
	Guide roller (GR attachment)	Guide rollers prevent meandering and can be used as running rollers. (This is not a curved chain.)	26
	Threaded extended pin (EN attachment)	The extended pin (tempered steel) is threaded for attaching jigs using nuts.	27
	Extended pin with clip (EC attachment)	Jigs can be attached with clips.	28
	Stay pin (ST attachment)	Pins are made longer to form parallel strands of chain. Ideal for conveying items on top of the pins, such as by attaching a mesh net.	29, 30
	Triangle attachment (RE attachment)	This chain is ideal for conveying a variety of bar-like items.	31
	Sticker attachment (FS attachment)	This chain, with its pointy triangular attachments, is perfect for gripping and conveying belt shaped items (film, etc.).	31
	Gripper attachment (KU, KUM)	Chain for gripping and conveying film, etc. with clips.	32
	Magnet attachment (MG)	Magnets attract cases carrying conveyed goods, allowing them to be conveyed at an incline.	33
	Rubber pad attachment (RSG)	A layer of rubber is bonded to the attachment. The elasticity of rubber allows objects to be conveyed between chains.	33
	Crescent top plate (CL attachment)	For horizontal circular conveyance.	34
	Slat (SLT [riveted] attachment)	Strong double pitch chain with slats attached. Perfect for conveying relatively heavy items.	34
	Slat (SLW [welded] attachment)	Double pitch chain with slats welded on. Perfect for conveying relatively heavy items.	35
	RS® slat (SLT [riveted] attachment)	Small pitch RS chain with a small distance between slats. Ideal for conveying small items. The small pitch also provides smooth operation.	35
	Pusher (SD attachment)	Perfect chain for directly pushing items to be conveyed.	36
	Top plate with bonded rubber pad (PSG attachment)	Rubber pads have been bonded onto the top plates to prevent scratching items.	37
	Tempered top plate (HTP attachment)	Steel top plates are hardened and tempered to minimize scratching.	37
Bent end top plate (SM attachment)	Enables smooth lateral transfer of conveyed items.	38	
Inclined top plate (30°) (CTP attachment)	The space between the upper faces of the slats are small, preventing conveyed items from getting caught.	38	

Quick Delivery Stocked parts for quick delivery.

Chain incorporating attachments with the most typical special hole diameters (equivalent to JIS-2 class bolt holes) from amongst our numerous attachments.

● Double Pitch **Special Hole Diameter Attachment (A & K attachments)** ● Standard chain ● Lambda chain (lube-free)

A1 Attachment

A2 Attachment

K1 Attachment

K2 Attachment

• Connecting links: RF2040 to RF2060 use spring clips. RF2080 and larger use cotter pins. Base chain pins are riveted.
 • Attachments shown are S roller types. However, the dimensions for attachments are the same when R rollers are used. Also, the drawings show attachments added on every link.
 • Pins other than those on connecting links are riveted regardless of whether attachments are present. • X and X₂ are the width of the attachments installed on the inner link.

Attachment Dimensions

Tsubaki Chain No.		Pitch P	Inner Link Inner Width W	Roller Dia.		Pin			Plate		Attachment						
Standard	Lambda			S Roller	R Roller	Dia D	L ₁	L ₂	Width H	Thickness T	C	K	N	S	X	X ₂	O
RF2040	RF2040-LMC	25.40	7.95	7.92	15.88	3.97	8.25	9.95	12.0	1.5	12.7	9.5	19.1	9.1	19.3	17.6	4.5 · 5.5
RF2050	RF2050-LMC	31.75	9.53	10.16	19.05	5.09	10.30	12.0	15.0	2.0	15.9	11.9	23.8	11.1	24.2	22.0	4.5 · 5.5
RF2060	RF2060-LMC	38.10	12.70	11.91	22.23	5.96	14.55	16.55	17.2	3.2	21.45	14.3	28.6	14.7	31.5	28.2	5.5 · 6.5
RF2080	RF2080-LMC	50.80	15.88	15.88	28.58	7.94	18.30	20.90	23.0	4.0	27.8	19.1	38.1	19.1	40.7	36.6	9.0
RF2100	RF2100-LMC	63.50	19.05	19.05	39.69	9.54	21.80	24.50	28.6	4.8	33.35	23.8	47.6	23.4	49.9	44.9	11.0

Chain Numbering

Special Hole Diameter (Double Pitch)

RF2040R-LMC-1LK1-5.5

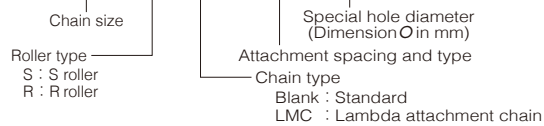

Connecting Link (CL)

RF2040-LMC-K1-5.5JL

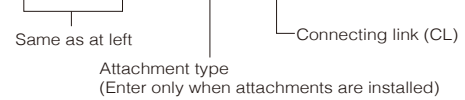

● RS **Special Hole Diameter Attachment (A & K attachments)** ● Standard chain ● Lambda chain (lube-free)

A1 Attachment

K1 Attachment

• Connecting links: RS35 to RS60 use spring clips. RS80 and larger use cotter pins. Base chain pins are riveted.
 • X and X₂ are the width of the attachments installed on the inner link.
 • The drawings show attachments added on every link.
 • Pins other than those on connecting links are riveted regardless of whether attachments are present.

Attachment Dimensions

Tsubaki Chain No.		Pitch P	Inner Link Inner Width W	Roller (Bush) Dia. R	Pin			Plate		Attachment					
Standard	Lambda				Dia D	L ₁	L ₂	Width H	Thickness T	C	N	S	X	X ₂	O
RS35	RS35-LMC	9.525	4.78	(5.08)	3.59/3.00	5.85	6.85	9.0	1.25	9.5	7.9	6.35	14.3	14.3	2.6
RS40	RS40-LMC	12.70	7.95	7.92	3.97	8.25	9.95	12.0	1.5	12.7	9.5	8.0	17.8	17.8	4.5 · 5.5
RS50	RS50-LMC	15.875	9.53	10.16	5.09	10.3	12.0	15.0	2.0	15.9	12.7	10.3	23.4	23.4	4.5 · 5.5
RS60	RS60-LMC	19.05	12.70	11.91	5.96	12.85	14.75	18.1	2.4	19.05	15.9	11.9	28.2	28.2	5.5 · 6.5
RS80	RS80-LMC	25.40	15.88	15.88	7.94	16.25	19.25	24.1	3.2	25.4	19.1	15.9	36.6	36.6	9.0
RS100	RS100-LMC	31.75	19.05	19.05	9.54	19.75	22.85	30.1	4.0	31.75	25.4	19.8	44.9	44.9	11.0

Note: RS35-LMC Lambda pin diameter is 3.00mm

Chain Numbering

Special Hole Diameter (RS)

RS40-LMC-1LA1-4.5

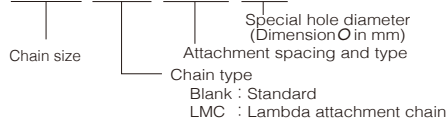

Connecting Link (CL)

RS40-LMC-A1-4.5JL



Quick Delivery Stocked parts for quick delivery.

Nuts are added on the attachment to enable slats to be installed simply and easily. Both the attachments and nuts are heat treated for ample strength.

 **Press Nut Attachment (Attachment types: A-NM & K-NM)** ● Standard chain ● Lambda chain (lube-free)

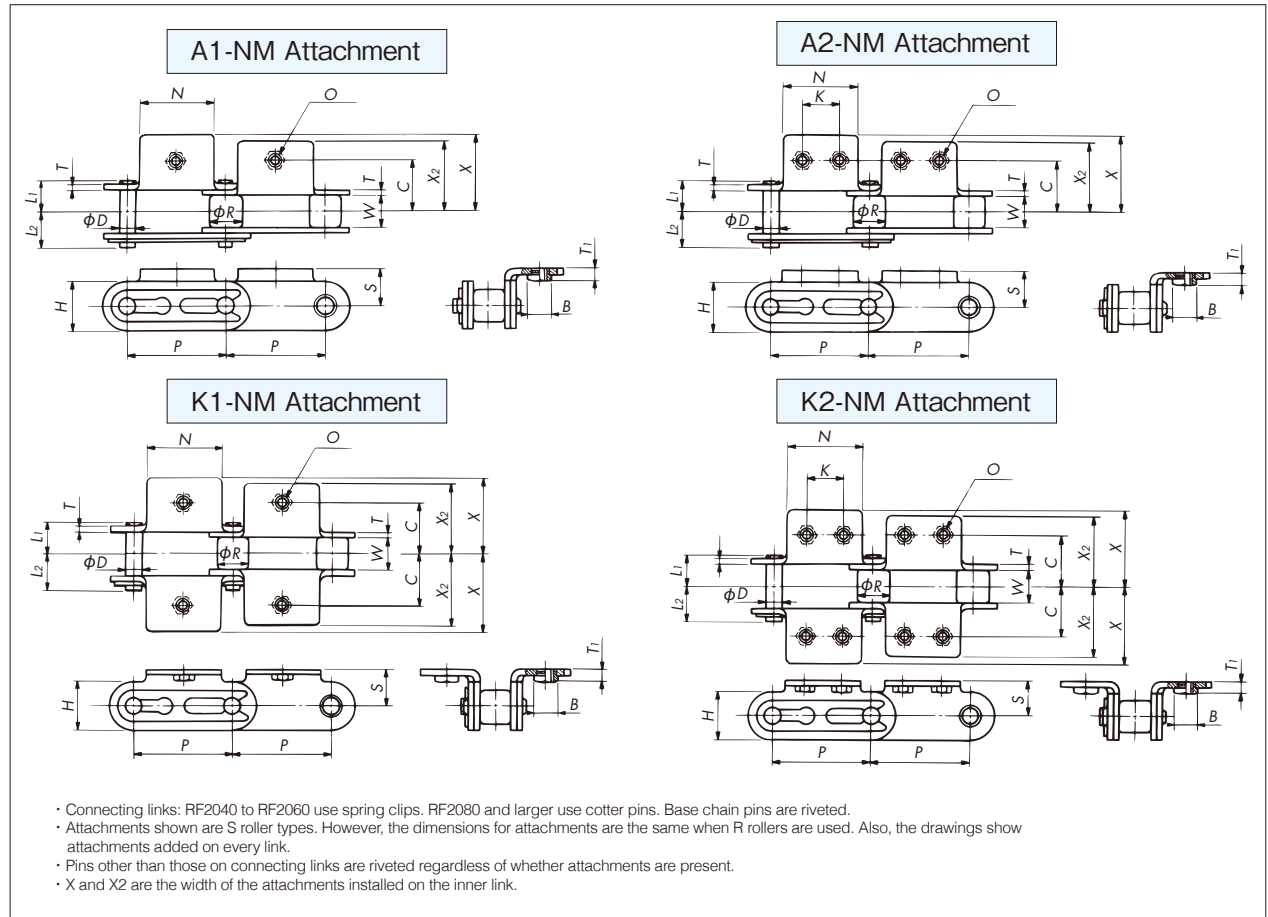

Attachment Dimensions

Tsubaki Chain No.		Pitch P	Inner Link Inner Width W	Roller Dia.		Pin			Plate		Attachment								
Standard	Lambda			S Roller	R Roller	Dia D	L1	L2	Width H	Thickness T	C	K	N	B	S	X	X2	T1	O
RF2040-NM3	RF2040-LMC-NM3	25.40	7.95	7.92	15.88	3.97	8.25	9.95	12.0	1.5	12.7	9.5	19.1	5.5	9.1	19.3	17.6	3.6	M3
RF2040-NM4	RF2040-LMC-NM4	25.40	7.95	7.92	15.88	3.97	8.25	9.95	12.0	1.5	12.7	9.5	19.1	7.0	9.1	19.3	17.6	3.8	M4
RF2050-NM4	RF2050-LMC-NM4	31.75	9.53	10.16	19.05	5.09	10.3	12.0	15.0	2.0	15.9	11.9	23.8	7.0	11.1	24.2	22.0	4.3	M4
RF2050-NM5	RF2050-LMC-NM5	31.75	9.53	10.16	19.05	5.09	10.3	12.0	15.0	2.0	15.9	11.9	23.8	8.0	11.1	24.2	22.0	5.1	M5
RF2060-NM5	RF2060-LMC-NM5	38.10	12.70	11.91	22.23	5.96	14.55	16.55	17.2	3.2	21.45	14.3	28.6	8.0	14.7	31.5	28.0	6.3	M5
RF2060-NM6	RF2060-LMC-NM6	38.10	12.70	11.91	22.23	5.96	14.55	16.55	17.2	3.2	21.45	14.3	28.6	10.0	14.7	31.5	28.0	7.3	M6

Dimension B is the width when nuts are installed on upper and lower surfaces.

Chain Numbering

Press Nut (Double Pitch)

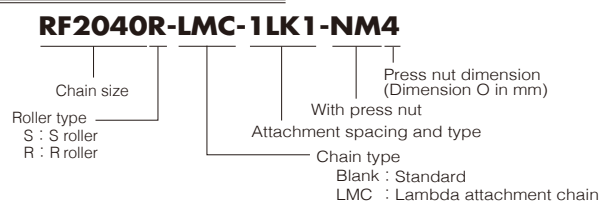

Connecting Link (CL)



RS Press Nut Attachment (Attachment types: A-NM & K-NM) ● Standard chain ● Lambda chain (lube-free)

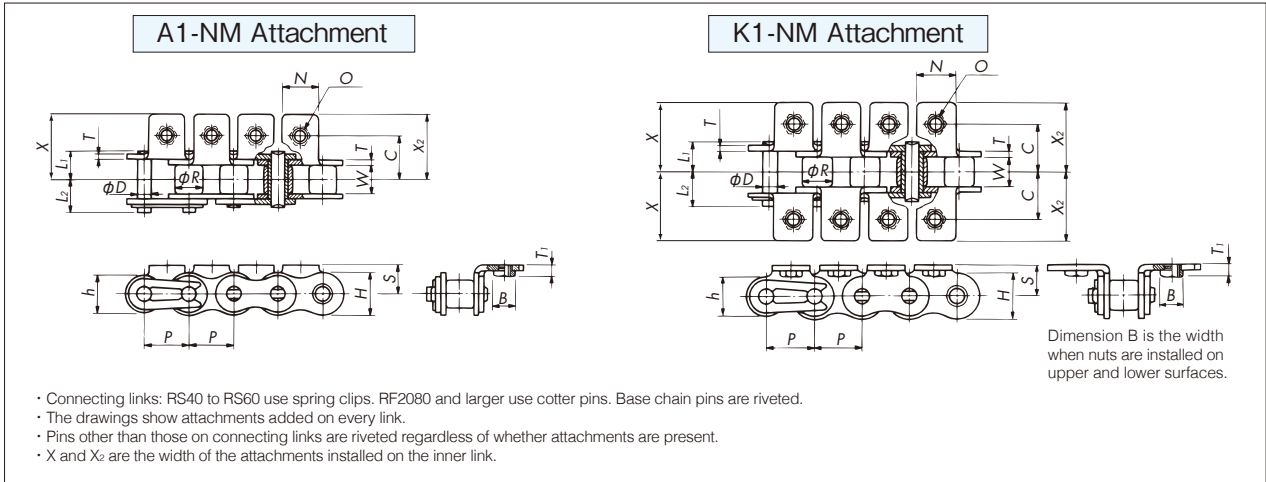

Attachment Dimensions

Tsubaki Chain No.		Pitch P	Inner Link Inner Width W	Roller Dia R	Pin			Plate			Attachment							
Standard	Lambda				Dia D	L ₁	L ₂	Width h	Width H	Thickness T	C	N	B	S	X	X ₂	T ₁	O
RS40-NM3	RS40-LMC-NM3	12.70	7.95	7.92	3.97	8.25	9.95	10.4	12.0	1.5	12.7	9.5	5.5	8.0	17.8	17.8	3.6	M3
RS40-NM4	RS40-LMC-NM4	12.70	7.95	7.92	3.97	8.25	9.95	10.4	12.0	1.5	12.7	9.5	7.0	8.0	17.8	17.8	3.8	M4
RS50-NM4	RS50-LMC-NM4	15.875	9.53	10.16	5.09	10.3	12.0	13.0	15.0	2.0	15.9	12.7	7.0	10.3	23.4	23.4	4.3	M4
RS50-NM5	RS50-LMC-NM5	15.875	9.53	10.16	5.09	10.3	12.0	13.0	15.0	2.0	15.9	12.7	8.0	10.3	23.4	23.4	5.1	M5
RS60-NM5	RS60-LMC-NM5	19.05	12.70	11.91	5.96	12.85	14.75	15.6	18.1	2.4	19.05	15.9	8.0	11.9	28.2	28.2	5.5	M5
RS60-NM6	RS60-LMC-NM6	19.05	12.70	11.91	5.96	12.85	14.75	15.6	18.1	2.4	19.05	15.9	10.0	11.9	28.2	28.2	6.5	M6

Dimension B is the width when nuts are installed on upper and lower surfaces.

Chain Numbering

Press Nut (RS)

RS40-LMC-2LK1-NM4

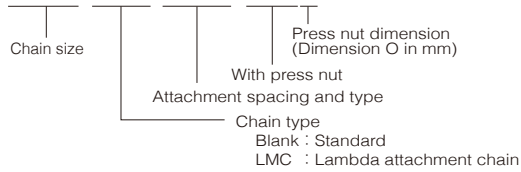

Connecting Link (CL)

RS40-LMC-K1-NM4JL

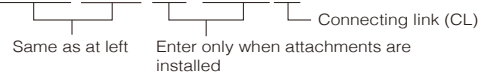

Quick Delivery Stocked parts for quick delivery

Chain with special extended pins with common parts so that they can be manufactured for shorter delivery times.

Double Pitch

Special Extended Pin (Attachment Type: EPL)

- Standard chain
- Lambda chain (lube-free)

EPL Attachment

• Actual dimension P' may differ from P. Contact a Tsubaki representative for details.
 • Extended pins on standard Lambda Chain are nickel-plated. Consequently, pin end diameter will be slightly larger.
 • Connecting links: RF2040 to RF2060 use spring clips. RF2080 and larger use cotter pins. Base chain pins are riveted.
 • Attachments shown are S roller types. However, the dimensions for attachments are the same when R rollers are used. Also, the drawings show attachments added on every link.
 • Pins other than those on connecting links are riveted regardless of whether attachments are present.

Attachment Dimensions

Tsubaki Chain No.		Pitch P	Inner Link Inner Width W	Roller Dia. R		Pin		Plate		Pin	
Standard	Lambda			S Roller	R Roller	Dia D	L ₂	Width H	Thickness T	L ₃	L ₄
RF2040-EPL15.4	RF2040-LMC-EPL15.4	25.40	7.95	7.92	15.88	3.97	9.95	12.0	1.5	15.4	22.65
RF2040-EPL20.3	RF2040-LMC-EPL20.3	25.40	7.95	7.92	15.88	3.97	9.95	12.0	1.5	20.3	27.55
RF2040-EPL29.8	RF2040-LMC-EPL29.8	25.40	7.95	7.92	15.88	3.97	9.95	12.0	1.5	29.8	37.05
RF2050-EPL19.3	RF2050-LMC-EPL19.3	31.75	9.53	10.16	19.05	5.09	12.0	15.0	2.0	19.3	28.4
RF2050-EPL23.8	RF2050-LMC-EPL23.8	31.75	9.53	10.16	19.05	5.09	12.0	15.0	2.0	23.8	32.9
RF2050-EPL31.2	RF2050-LMC-EPL31.2	31.75	9.53	10.16	19.05	5.09	12.0	15.0	2.0	31.2	40.3
RF2060-EPL16.5	RF2060-LMC-EPL16.5	38.10	12.70	11.91	22.23	5.96	16.55	17.2	3.2	16.5	29.65
RF2060-EPL20.8	RF2060-LMC-EPL20.8	38.10	12.70	11.91	22.23	5.96	16.55	17.2	3.2	20.8	33.95
RF2060-EPL28.2	RF2060-LMC-EPL28.2	38.10	12.70	11.91	22.23	5.96	16.55	17.2	3.2	28.2	41.35
RF2080-EPL27.1	RF2080-LMC-EPL27.1	50.80	15.88	15.88	28.58	7.94	20.90	23.0	4.0	27.1	43.5
RF2080-EPL35.4	RF2080-LMC-EPL35.4	50.80	15.88	15.88	28.58	7.94	20.90	23.0	4.0	35.4	51.8
RF2080-EPL56.5	RF2080-LMC-EPL56.5	50.80	15.88	15.88	28.58	7.94	20.90	23.0	4.0	56.5	72.9
RF2100-EPL34.0	RF2100-LMC-EPL34.0	63.50	19.05	19.05	39.69	9.54	24.50	28.6	4.8	34.0	53.6
RF2100-EPL43.7	RF2100-LMC-EPL43.7	63.50	19.05	19.05	39.69	9.54	24.50	28.6	4.8	43.7	63.3
RF2100-EPL69.9	RF2100-LMC-EPL69.9	63.50	19.05	19.05	39.69	9.54	24.50	28.6	4.8	69.9	89.5

Chain Numbering

Special Extended Pin (Double Pitch)

RF2040S-LMC-2LEPL15.4

Chain size

Roller type
S : S roller
R : R roller

Extended pin projection (L₃ in mm)
With extended pins

Extended pin spacing

Chain type
Blank : Standard
LMC : Lambda attachment chain

Connecting Link (CL)

RF2040-LMC-E1-L15.4JL

Same as at left

Same as at left

Connecting Link (CL)

E1 : One extended pin
E2 : Two extended pins

Same as at left



Special Extended Pin (Attachment Type: EPL)(RS)

- Standard chain
- Lambda chain (lube-free)

EPL Attachment

- Actual dimension P' may differ from P. Contact a Tsubaki representative for details.
- Extended pins on standard Lambda Chain are nickel-plated. Consequently, pin end diameter will be slightly larger.
- Connecting links: RS40 to RS60 use spring clips. RS80 and larger use cotter pins. Base chain pins are riveted.
- Attachments shown are S roller types. However, the dimensions for attachments are the same when R rollers are used. Also, the drawings show attachments added on every link.
- Pins other than those on connecting links are riveted regardless of whether attachments are present.

Attachment Dimensions

Tsubaki Chain No.		Pitch P	Inner Link Inner Width W	Roller Dia R	Pin			Plate			Pin	
Standard	Lambda				Dia D	L ₁	L ₂	Width h	Width H	Thickness T	L ₃	L ₄
RS40-EPL15.4	RS40-LMC-EPL15.4	12.70	7.95	7.92	3.97	8.25	9.95	10.4	12.0	1.5	15.4	22.7
RS40-EPL20.3	RS40-LMC-EPL20.3	12.70	7.95	7.92	3.97	8.25	9.95	10.4	12.0	1.5	20.3	27.6
RS40-EPL29.8	RS40-LMC-EPL29.8	12.70	7.95	7.92	3.97	8.25	9.95	10.4	12.0	1.5	29.8	37.1
RS50-EPL19.3	RS50-LMC-EPL19.3	15.875	9.53	10.16	5.09	10.3	12.0	13.0	15.0	2.0	19.3	28.4
RS50-EPL23.8	RS50-LMC-EPL23.8	15.875	9.53	10.16	5.09	10.3	12.0	13.0	15.0	2.0	23.8	32.9
RS50-EPL31.2	RS50-LMC-EPL31.2	15.875	9.53	10.16	5.09	10.3	12.0	13.0	15.0	2.0	31.2	40.3
RS60-EPL19.9	RS60-LMC-EPL19.9	19.05	12.70	11.91	5.96	12.85	14.75	15.6	18.1	2.4	19.9	31.45
RS60-EPL24.2	RS60-LMC-EPL24.2	19.05	12.70	11.91	5.96	12.85	14.75	15.6	18.1	2.4	24.2	35.75
RS60-EPL31.6	RS60-LMC-EPL31.6	19.05	12.70	11.91	5.96	12.85	14.75	15.6	18.1	2.4	31.6	43.15
RS80-EPL30.8	RS80-LMC-EPL30.8	25.40	15.88	15.88	7.94	16.25	19.25	20.8	24.1	3.2	30.8	45.55
RS80-EPL39.1	RS80-LMC-EPL39.1	25.40	15.88	15.88	7.94	16.25	19.25	20.8	24.1	3.2	39.1	53.9
RS80-EPL42.3	RS80-LMC-EPL42.3	25.40	15.88	15.88	7.94	16.25	19.25	20.8	24.1	3.2	42.3	57.05
RS100-EPL37.7	RS100-LMC-EPL37.7	31.75	19.05	19.05	9.54	19.75	22.85	26.0	30.1	4.0	37.7	55.65
RS100-EPL45.0	RS100-LMC-EPL45.0	31.75	19.05	19.05	9.54	19.75	22.85	26.0	30.1	4.0	45.0	62.95
RS100-EPL50.7	RS100-LMC-EPL50.7	31.75	19.05	19.05	9.54	19.75	22.85	26.0	30.1	4.0	50.7	68.65

Chain Numbering

Special Extended Pin (RS)

RS40-LMC-1LEPL15.4

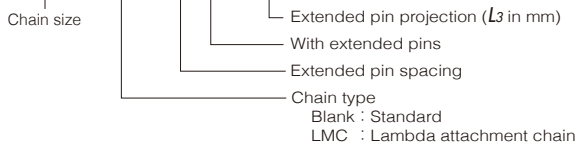

Connecting Link (CL)

RS40-LMC-E1-L15.4JL

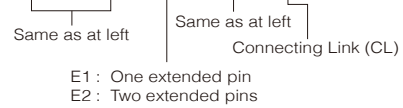

Design Stock

Design stock of reliable designs. Selecting from among these designs will improve overall design efficiency for your application.

The upper surfaces of the link plates and the outside of the rollers have been ground.



Double Pitch

Ground Surface Attachment (Attachment Type: PG)

A1 Attachment

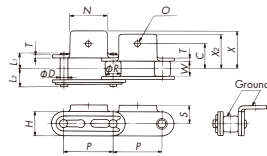

A2 Attachment

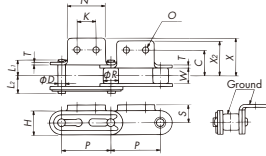

K1 Attachment

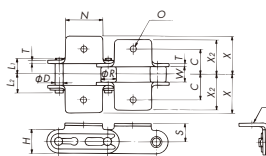

K2 Attachment

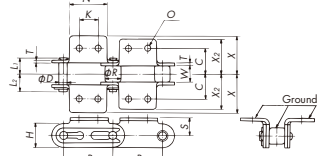

- X and X₂ are the width of the attachments installed on the inner link.
- The drawings show attachments added on every link.
- Pins other than those on connecting links are riveted regardless of whether attachments are present.

Chain Numbering

RF2040S-PG-2LK1

Attachment Dimensions

Tsubaki Chain No.	Pitch P	Inner Link Inner Width W	Roller Dia. R		Pin			Plate			Attachment						Connecting Link Type
			S Roller	R Roller	Dia D	L ₁	L ₂	Width H	Thickness T	C	K	N	O	S	X	X ₂	
RF2040-PG	25.40	7.95	7.90	15.80	3.97	8.25	9.95	12.0	1.5	12.7	9.5	19.1	3.6	8.9	19.3	17.6	Spring clip
RF2050-PG	31.75	9.53	10.12	18.97	5.09	10.30	12.0	15.0	2.0	15.9	11.9	23.8	5.2	10.9	24.2	22.0	Spring clip
RF2060-PG	38.10	12.70	11.88	22.15	5.96	14.55	16.55	17.2	3.2	21.45	14.3	28.6	5.2	14.4	31.5	28.2	Spring clip
RF2080-PG	50.80	15.88	15.71	28.50	7.94	18.30	20.9	23.0	4.0	27.8	19.1	38.1	6.8	18.8	40.7	36.6	Cotter pin

- Note: 1. Chains without attachments are available only with S rollers.
 2. On chains without attachments, the outer surface of the rollers is not ground. In this case, the roller diameters will differ from the dimensions given above. Roller diameter (R) for RF2040 is 7.92; RF2050S is 10.16; RF2060S is 11.91, and RF2080S is 15.88.
 3. The top surface of the link plates is ground on chains without attachments. In this case, the plate widths H will differ from the dimensions given above. Width (H) for RF2040S is 11.9; RF2050S is 14.9; RF2060S is 17.1; and RF2080S is 22.7.



RS

Ground Surface Attachment (Attachment Type: PG)

A1 Attachment

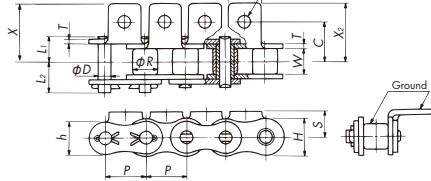

K1 Attachment

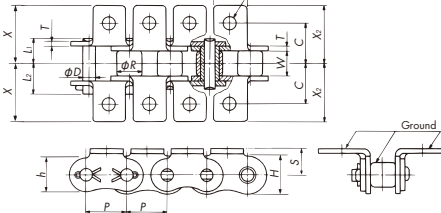

Chain Numbering

RS40-PG-1LK1

Chain size | Attachment type
 Ground attachment | Attachment Spacing

- X and X₂ are the width of the attachments installed on the inner link.
- The drawings show attachments added on every link.
- Pins other than those on connecting links are riveted regardless of whether attachments are present.

Attachment Dimensions

Tsubaki Chain No.	Pitch P	Inner Link Inner Width W	Roller Dia R	Pin			Plate			Attachment					Connecting Link Type
				Dia D	L ₁	L ₂	Width h	Width H	Thickness T	C	N	O	S	X	
RS40-PG	12.70	7.95	7.90	3.97	8.25	9.95	10.4	12.0	1.5	12.7	9.5	3.6	7.8	17.8	Spring clip
RS50-PG	15.875	9.53	10.12	5.09	10.3	12.0	13.0	15.0	2.0	15.9	12.7	5.2	10.1	23.4	Spring clip
RS60-PG	19.05	12.70	11.88	5.96	12.85	14.75	15.6	18.1	2.4	19.05	15.9	5.2	11.6	28.2	Spring clip
RS80-PG	25.40	15.88	15.71	7.94	16.25	19.25	20.8	24.1	3.2	25.4	19.1	6.8	15.6	36.6	Cotter pin
RS100-PG	31.75	19.05	18.83	9.54	19.75	22.85	26.0	30.1	4.0	31.75	25.4	8.7	19.4	44.9	Cotter pin
RS120-PG	38.10	25.40	22.01	11.11	24.9	28.9	31.2	36.2	4.8	38.1	28.6	10.3	22.6	55.8	Cotter pin
RS140-PG	44.45	25.40	25.18	12.71	26.9	31.7	36.4	42.2	5.6	44.5	34.9	11.9	28.2	63.1	Cotter pin
RS160-PG	50.80	31.75	28.36	14.29	31.85	36.85	41.6	48.2	6.4	50.8	38.1	14.3	31.4	73.7	Cotter pin

- Note: X and X₂ are the widths of the attachments installed on the outer (pin) link and inner (roller) link, respectively.
 (For RS40 to RS100, X=X₂; for RS120, X₂=51.2; for RS140, X₂=58.0, and for RS160, X₂=66.0)



RS® Large Size Chain with Attachment

Attachments for chain sizes RS180 and larger.

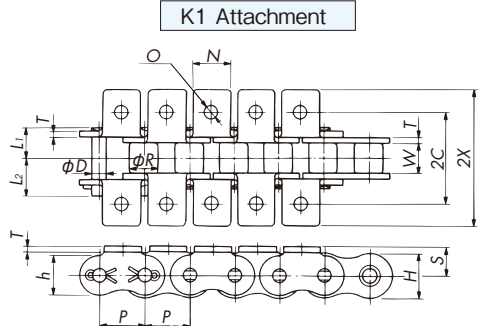

Applicable chain sizes: RS180, RS200, RS240, RF320-T, and RF400-T. Drawing shows RS180/RS200. External appearance will differ for sizes RS240 and larger.

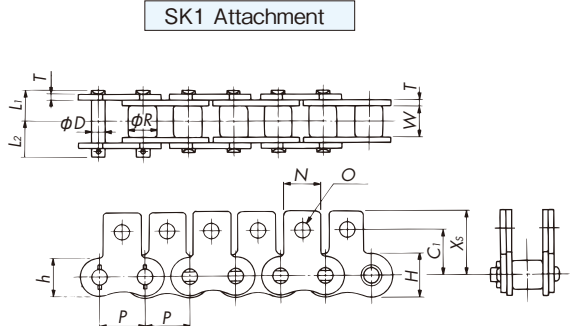

Applicable chain sizes: RS200 and RS240. Drawing shows RS240. Connecting links for RS200 use cotter pins.

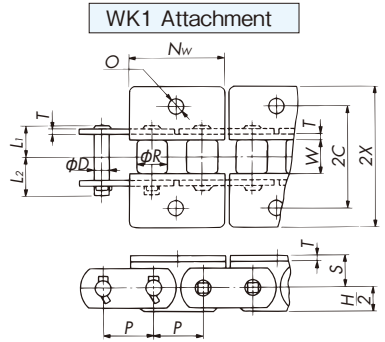

Applicable chain size is RF400-T.

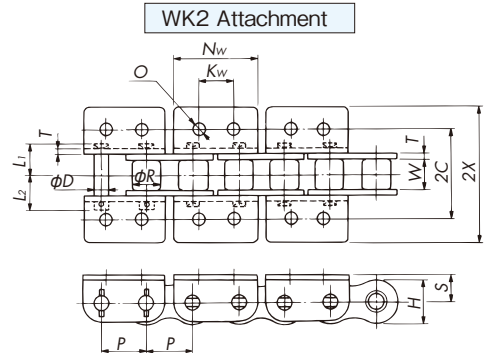

Applicable chain size: RS200 and RS240.

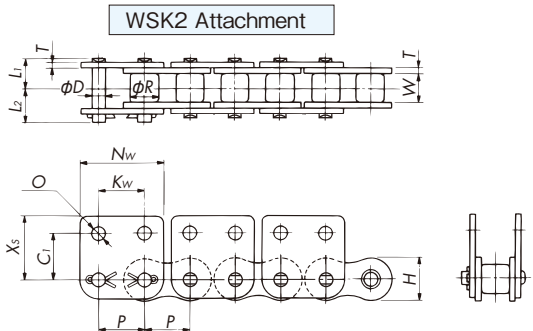

Applicable chain size: RS200, RS240, and RF400-T. Drawing shows RS200. External appearance for other sizes will differ.

Chain Numbering

RS180-1LK1

Chain size | Attachment type
Attachment Spacing

Attachment Types and Attaching Links

Tsubaki Chain No.	K1	SK1	WK1	WK2	WSK2
RS180	PL or RL	—	—	—	—
RS200	PL or RL	PL	—	PL	PL
RS240	PL or RL	PL or RL	—	PL	PL
RF320-T	PL	—	—	—	—
RF400-T	PL	—	RL	—	PL

PL: Outer link, RL: Inner link

Attachment Dimensions

Tsubaki Chain No.	Pitch P	Roller Dia R	Inner Link Inner Width W	Pin			Plate			2C	C1	N	O	S	2X	Xs	Nw	Kw
				Dia D	L1	L2	h	H	T									
RS180	57.15	35.71	35.72	17.46	35.65	42.45	46.8	54.2	7.15	114.3	—	42.0	15.0	35.8	160.3	—	—	—
RS200	63.50	39.68	38.10	19.85	39.0	44.8	52.0	60.3	8.0	127.0	63.5	48.0	17.5	42.9	167.0	85.5	115.4	63.5
RS240	76.20	47.63	47.63	23.81	47.9	55.5	62.4	72.4	9.5	152.4	76.2	57.2	21.0	47.7	195.8	106.7	138.5	57.0
RF320-T	101.6	63.5	63.65	31.75	63.8	77.6	—	92	12.7	203.2	—	76.2	25.4	85.5	281.3	—	—	—
RF400-T	127.0	79.38	79.3	39.68	79.65	92.65	—	120	16.0	254.0	120	101.6	38.0	79.4	356.0	180	245	127



Design Stock

Design stock of reliable designs. Selecting from among these designs will improve overall design efficiency for your application.



Double Pitch

Double Pitch Deep Link (Attachment Type: DL)

The height of the link plates (dimension H1) is higher than the top of the rollers on a double pitch base chain. Allows materials to be placed directly on the chain, even with R rollers.

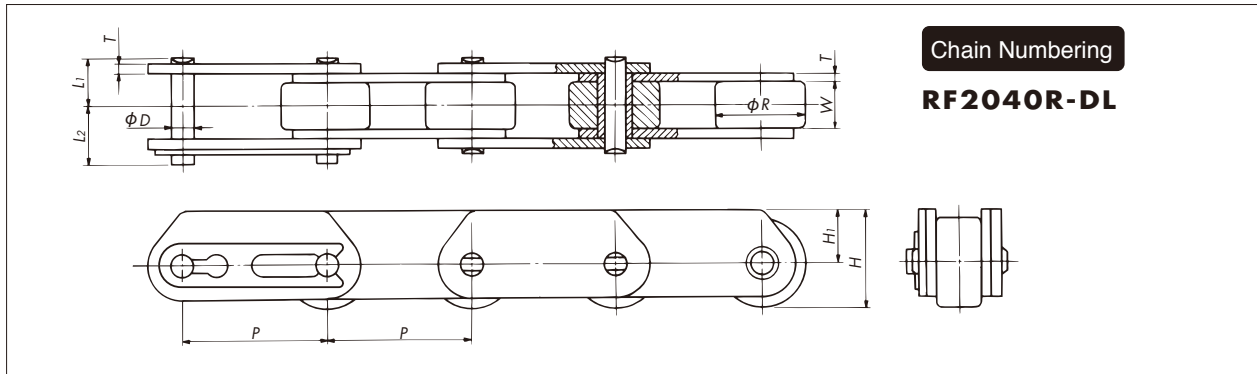

Attachment Dimensions

Tsubaki Chain No.	Pitch P	Inner Link Inner Width W	Roller Dia R	Chain Height H	Pin			Plate		Connecting Link Type
					Dia D	L1	L2	Width H1	Thickness T	
RF2040R-DL	25.40	7.95	15.88	(17.9)	3.97	8.25	9.95	10.0	1.5	Spring clip
RF2050R-DL	31.75	9.53	19.05	(21.5)	5.09	10.3	12.0	12.0	2.0	Spring clip
RF2060R-DL	38.10	12.70	22.23	(25.1)	5.96	14.55	16.55	14.0	3.2	Spring clip
RF2080R-DL	50.80	15.88	28.58	(32.2)	7.94	18.30	20.90	18.0	4.0	Cotter pin



RS

Inwardly Bent Attachment

Conveyed materials can be placed directly or sandwiched between the inwardly bent attachments. The top edges are chamfered to protect conveyed materials from scratches.

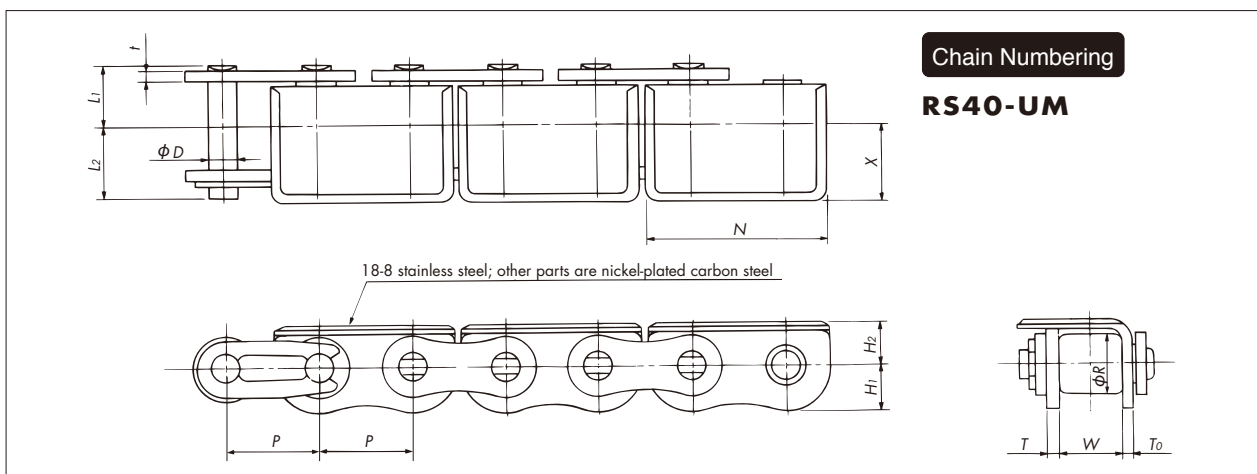

Attachment Dimensions

Tsubaki Chain No.	Pitch P	Inner Link Inner Width W	Roller Dia R	Pin			Plate						
				Dia D	L1	L2	H1	H2	N	X	T	t	To
RS40-UM	12.70	7.95	7.92	3.97	8.25	9.95	7.0	5.7	24.4	11.3	1.5	1.5	1.25
RS50-UM	15.875	9.53	10.16	5.09	10.3	12.0	8.5	7.1	30.5	13.1	2.0	2.0	1.5

- When used as a replacement chain, carefully check dimension H2 to avoid possible interference.
- Maximum allowable load differs from RS attachment chain. Contact a Tsubaki representative for details.

Guide rollers prevent meandering and can be used as running rollers. (Not a curved chain.)

Double Pitch
Guide Roller (Attachment Type: GR)

Chain Numbering

RF2040R-2LGR

- Chain size
- Roller type S,R
- Guide roller spacing
- With guide roller

• Connecting links: RF2040 to RF2060 use spring clips. RF2080 and RF2100 use cotter pins.
 • Attachments shown are R roller types. However, the dimensions for attachments are the same when S rollers are used.

Attachment Dimensions

Tsubaki Chain No.	Pitch P	Inner Link Inner Width W	Roller Dia. R		Pin			Plate		Attachment				Guide Roller		
			S Roller	R Roller	Dia D	L1	L2	Width H	Thickness T	C	X	N	Y	d	Df	ℓ
RF2040-GR	25.40	7.95	7.92	15.88	3.97	8.25	9.95	12.0	1.5	17.45	22.20	9.5	13.2	3.97	15.88	7.8
RF2050-GR	31.75	9.53	10.16	19.05	5.09	10.30	12.00	15.0	2.0	21.15	27.50	12.7	16.2	5.09	19.05	9.4
RF2060-GR	38.10	12.70	11.91	22.23	5.96	14.55	16.55	17.2	3.2	27.00	34.95	15.9	22.2	5.96	22.23	12.6
RF2080-GR	50.80	15.88	15.88	28.58	7.94	18.30	20.90	23.0	4.0	33.35	42.90	19.1	27.4	7.94	28.58	15.8
RF2100-GR	63.50	19.05	19.05	39.69	9.54	21.80	24.50	28.6	4.8	42.85	55.55	25.4	32.7	9.54	39.69	19.0

RS
Guide Roller (Attachment Type: GR)

Chain Numbering

RS40-2LGR

- Chain size
- With guide roller
- Guide roller spacing

Note: Connecting links: RS40 to RS60 use spring clips. RS80 and RS100 use cotter pins.

Attachment Dimensions

Tsubaki Chain No.	Pitch P	Inner Link Inner Width W	Roller Dia R	Pin			Plate		Attachment				Guide Roller		
				Dia D	L1	L2	Width H	Thickness T	C	X	N	Y	d	Df	ℓ
RS40-GR	12.70	7.95	7.92	3.97	8.25	9.95	12.0	1.5	17.45	22.20	9.5	16.5	3.97	15.88	11.05
RS50-GR	15.875	9.53	10.16	5.09	10.30	12.00	15.0	2.0	21.15	27.50	12.7	20.6	5.09	19.05	13.75
RS60-GR	19.05	12.70	11.91	5.96	12.85	14.75	18.1	2.4	25.40	33.35	15.9	25.7	5.96	22.23	17.65
RS80-GR	25.40	15.88	15.88	7.94	16.25	19.25	24.1	3.2	31.75	41.30	19.1	32.5	7.94	28.58	22.50
RS100-GR	31.75	19.05	19.05	9.54	19.75	22.85	30.1	4.0	41.30	54.00	25.4	39.5	9.54	39.69	27.40

Design Stock

Design stock of reliable designs. Selecting from among these designs will improve overall design efficiency for your application.

Extended pins (high-strength/hardened steel) are threaded to enable tools, jigs, and so on to be attached. Mounting a tool or jig that straddles two pins is constrained by P' , the distance between pin centerlines. Contact a Tsubaki representative regarding dimension P' .



Double Pitch

Threaded Extended Pin (Attachment Type: EN)

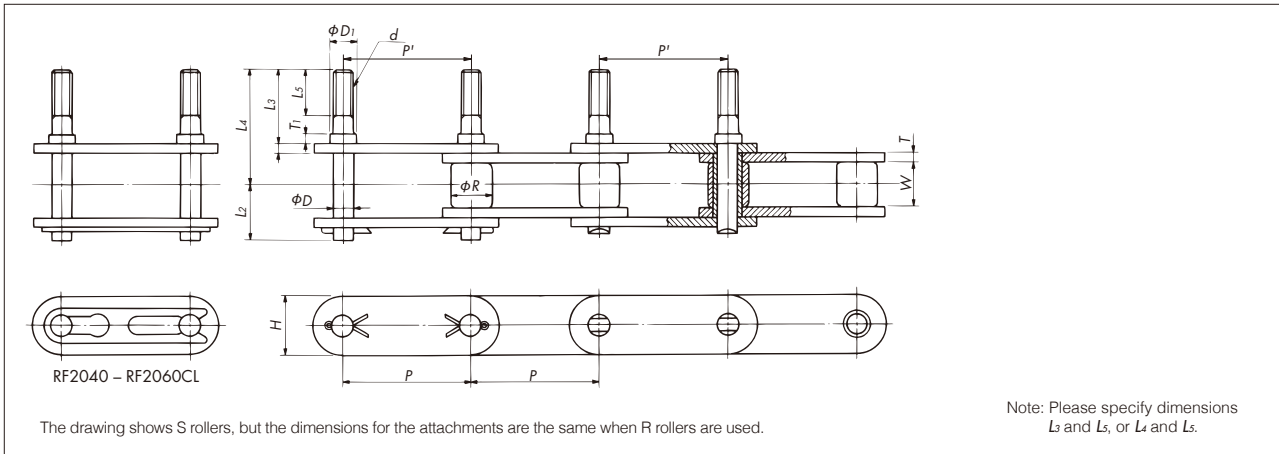

Attachment Dimensions

Tsubaki Chain No.		Pitch P	Inner Link Inner Width W	Roller Dia. R		Pin					Plate		Connecting Link Type
				S Roller	R Roller	Dia D	D_1	d	T_1	L_2	Width H	Thickness T	
RF2040S-EN	RF2040R-EN	25.40	7.95	7.92	15.88	3.97	5.00	M4	1.5	9.95	12.0	1.5	Spring clip
RF2050S-EN	RF2050R-EN	31.75	9.53	10.16	19.05	5.09	6.35	M5	2.0	12.0	15.0	2.0	Spring clip
RF2060S-EN	RF2060R-EN	38.10	12.70	11.91	22.23	5.96	8.35	M6	2.4	16.55	17.2	3.2	Spring clip
RF2080S-EN	RF2080R-EN	50.80	15.88	15.88	28.58	7.94	9.88	M8	3.2	20.90	23.0	4.0	Cotter pin
RF2100S-EN	RF2100R-EN	63.50	19.05	19.05	39.69	9.54	11.46	M10	4.0	24.50	28.6	4.8	Cotter pin



RS

Threaded Extended Pin (Attachment Type: EN)

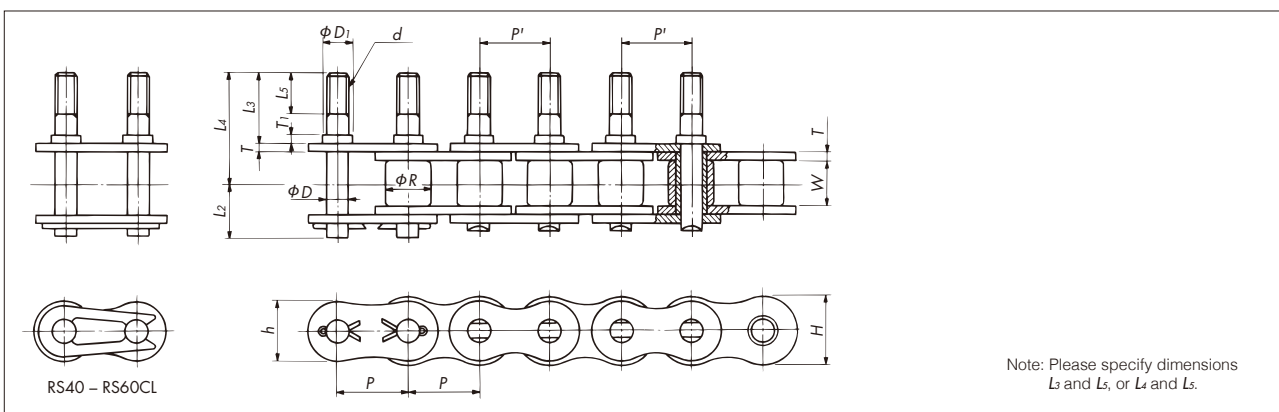

Attachment Dimensions

Tsubaki Chain No.	Pitch P	Inner Link Inner Width W	Roller Dia R	Pin					Plate			Connecting Link Type
				Dia D	D_1	d	T_1	L_2	Width h	Width H	Thickness T	
RS40-EN	12.70	7.95	7.92	3.97	5.00	M4	1.5	9.95	10.4	12.0	1.5	Spring clip
RS50-EN	15.875	9.53	10.16	5.09	6.35	M5	2.0	12.0	13.0	15.0	2.0	Spring clip
RS60-EN	19.05	12.70	11.91	5.96	8.35	M6	2.4	14.75	15.6	18.1	2.4	Spring clip
RS80-EN	25.40	15.88	15.88	7.94	9.88	M8	3.2	19.25	20.8	24.1	3.2	Cotter pin
RS100-EN	31.75	19.05	19.05	9.54	11.46	M10	4.0	22.85	26.0	30.1	4.0	Cotter pin
RS120-EN	38.10	25.40	22.23	11.11	13.07	M12	4.8	28.90	31.2	36.2	4.8	Cotter pin

Tools and so on can be attached on the extended pins and locked by using the spring clips .
 Mounting a tool or jig that straddles two pins is constrained by P' , the distance between pin centerlines.
 Contact a Tsubaki representative regarding dimension P' .



Double Pitch

Extended Pin with Spring Clip (Attachment Type: EC)

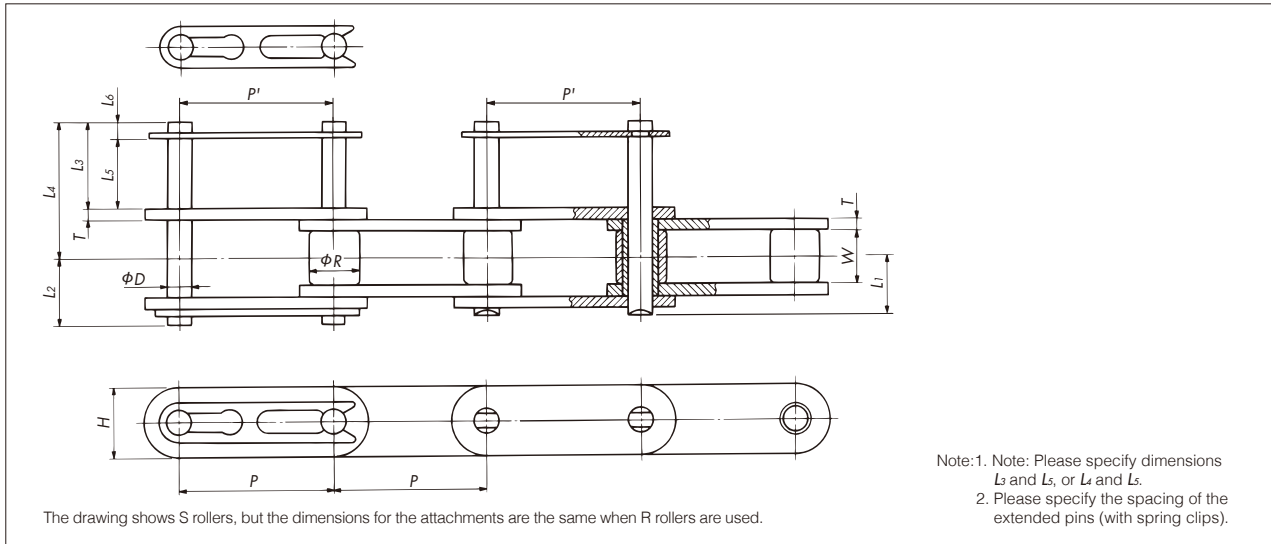

Attachment Dimensions

Tsubaki Chain No.	Pitch P	Inner Link Inner Width W	Roller Dia. R		Pin			Plate		Connecting Link Type		
			S Roller	R Roller	Dia D	L_1	L_2	L_6	Width H		Thickness T	
RF2040S-EC	RF2040R-EC	25.40	7.95	7.92	15.88	3.97	8.25	9.95	(2.8)	12.0	1.5	Spring clip
RF2050S-EC	RF2050R-EC	31.75	9.53	10.16	19.05	5.09	10.3	12.0	(3.0)	15.0	2.0	Spring clip
RF2060S-EC	RF2060R-EC	38.10	12.70	11.91	22.23	5.96	14.55	16.55	(3.4)	17.2	3.2	Spring clip



RS

Extended Pin with Spring Clip (Attachment Type: EC)

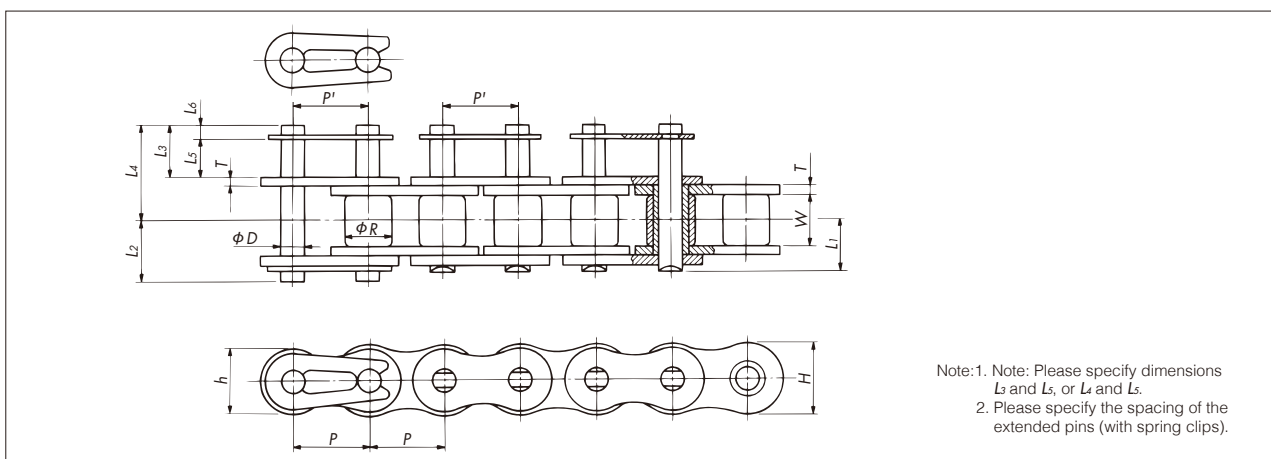

Attachment Dimensions

Tsubaki Chain No.	Pitch P	Inner Link Inner Width W	Roller Dia. R	Pin			Plate			Connecting Link Type	
				Dia D	L_1	L_2	L_6	Width h	Width H		Thickness T
RS40-EC	12.70	7.95	7.92	3.97	8.25	9.95	(2.8)	10.4	12.0	1.5	Spring clip
RS50-EC	15.875	9.53	10.16	5.09	10.3	12.0	(3.0)	13.0	15.0	2.0	Spring clip
RS60-EC	19.05	12.70	11.91	5.96	12.85	14.75	(3.4)	15.6	18.1	2.4	Spring clip

Design Stock

Design stock of reliable designs. Selecting from among these designs will improve overall design efficiency for your application.

Pins are made longer to form parallel strands of chain. Ideal for conveying items on top of the pins, such as by attaching a mesh net.



Stay Pin (Attachment Type: ST)

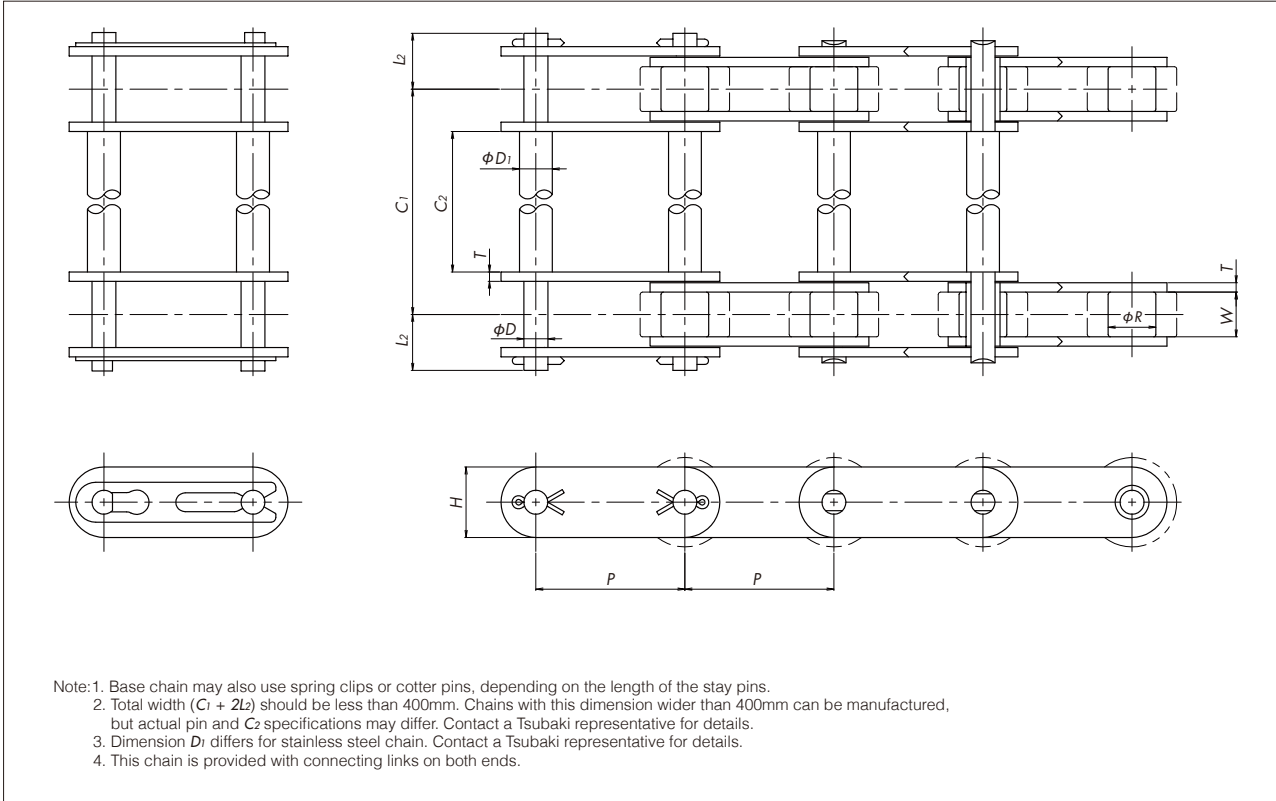

Attachment Dimensions

Tsubaki Chain No.		Pitch P	Inner Link Inner Width W	Roller Dia. R		Pin				Plate		Connecting Link Type
				S Roller	R Roller	Dia D	D_1	L_2	C_1, C_2	Width H	Thickness T	
RF2040S-ST	RF2040R-ST	25.40	7.95	7.92	15.88	3.97	5.84<5.2>	9.95	Specify dimension C_1 or C_2	12.0	1.5	Spring clip
RF2050S-ST	RF2050R-ST	31.75	9.53	10.16	19.05	5.09	6.35<6.1>	12.0		15.0	2.0	Spring clip
RF2060S-ST	RF2060R-ST	38.10	12.70	11.91	22.23	5.96	8.35<8.07>	16.55		17.2	3.2	Spring clip
RF2080S-ST	RF2080R-ST	50.80	15.88	15.88	28.58	7.94	9.88	20.90		23.0	4.0	Cotter pin
RF2100S-ST	RF2100R-ST	63.50	19.05	19.05	39.69	9.54	11.46	24.50		28.6	4.8	Cotter pin
RF2120S-ST	RF2120R-ST	76.20	25.40	22.23	44.45	11.11	13.07	30.55		34.4	5.6	Cotter pin
RF2160S-ST	RF2160R-ST	101.60	31.75	28.58	57.15	14.29	17.90	38.45		48.2	7.15	Cotter pin

Note: Figures inside <> are for stainless steel chain.



Stay Pin (Attachment Type: ST)

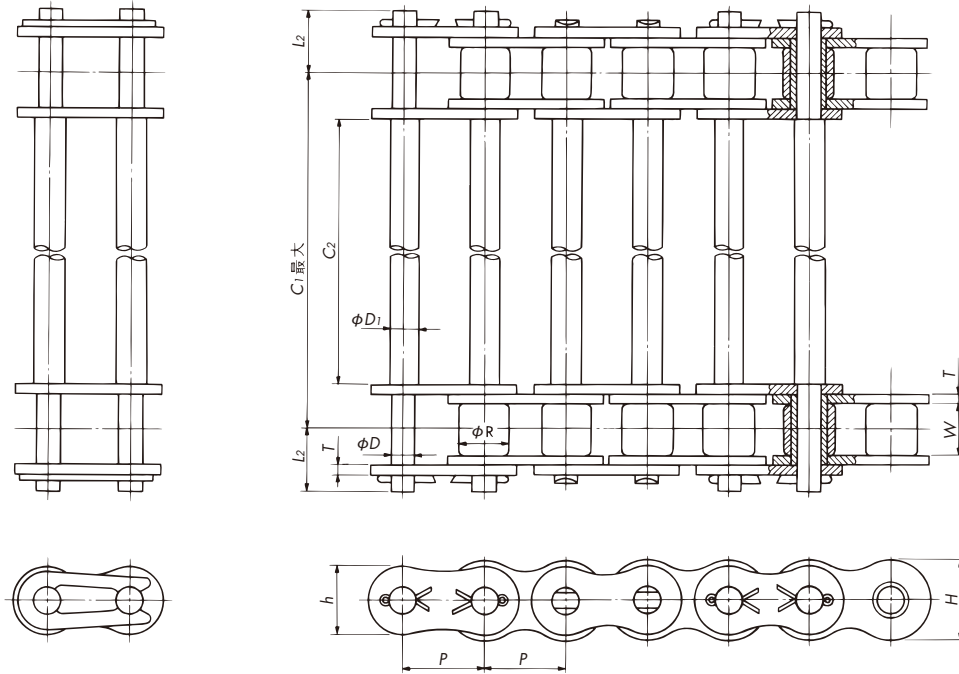

- Note: 1. Base chain may also use spring clips or cotter pins, depending on the length of the stay pins.
 2. Total width ($C_1 + 2L_2$) should be less than 400mm. Chains with this dimension wider than 400mm can be manufactured, but actual pin and C_2 specifications may differ. Contact a Tsubaki representative for details.
 3. Dimension D_1 differs for stainless steel chain. Contact a Tsubaki representative for details.
 4. This chain is provided with connecting links on both ends.

Attachment Dimensions

Tsubaki Chain No.	Pitch P	Inner Link Inner Width W	Roller Dia R	Pin				Plate			Connecting Link Type
				Dia D	D_1	L_2	C_1, C_2	Width h	Width H	Thickness T	
RS35-ST	9.525	4.78	(5.08)	3.59	5.0	6.85	Specify dimension C_1 or C_2	7.8	9.0	1.25	Spring clip
RS40-ST	12.70	7.95	7.92	3.97	5.84(<5.2)	9.95		10.4	12.0	1.5	Spring clip
RS50-ST	15.875	9.53	10.16	5.09	6.35(<6.1)	12.0		13.0	15.0	2.0	Spring clip
RS60-ST	19.05	12.70	11.91	5.96	8.35(<8.07)	14.75		15.6	18.1	2.4	Spring clip
RS80-ST	25.40	15.88	15.88	7.94	9.88	19.25		20.8	24.1	3.2	Cotter pin
RS100-ST	31.75	19.05	19.05	9.54	11.46	22.85		26.0	30.1	4.0	Cotter pin
RS120-ST	38.10	25.40	22.23	11.11	13.07	28.9		31.2	36.2	4.8	Cotter pin
RS140-ST	44.45	25.40	25.40	12.71	14.67	31.7		36.4	42.2	5.6	Cotter pin
RS160-ST	50.80	31.75	28.58	14.29	17.90	36.85		41.6	48.2	6.4	Cotter pin

Note: Roller diameter R (in parentheses) for RS35-ST is the bush diameter.
 Figures inside <> are for stainless steel.

Design Stock

Design stock of reliable designs. Selecting from among these designs will improve overall design efficiency for your application.



Triangle Attachment (Attachment Type: RE)

Ideal chain for conveying various types of bar-like attachments.

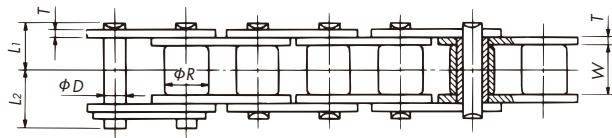

Chain Numbering

RS40-RE

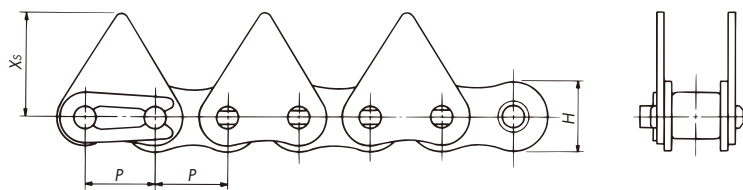

Contact a Tsubaki representative for other available attachment types. RS40 to RS60 use spring clips for the connecting links, while other sizes use cotter pins.

Attachment Dimensions

Tsubaki Chain No.	Pitch P	Inner Link Inner Width W	Roller Dia R	Pin			Plate		
				Dia D	L1	L2	Width H	Thickness T	Height Xs
RS40-RE	12.70	7.95	7.92	3.97	8.25	9.95	12.0	1.5	17.9
RS50-RE	15.875	9.53	10.16	5.09	10.3	12.0	15.0	2.0	23.5
RS60-RE	19.05	12.70	11.91	5.96	12.85	14.75	18.1	2.4	20.8
RS80-RE	25.40	15.88	15.88	7.94	16.25	19.25	24.1	3.2	29.0
RS100-RE	31.75	19.05	19.05	9.54	19.75	22.85	30.1	4.0	34.6



Sticker Attachment (Attachment Type: FS)

The attachment is topped with a sharp barb-like spike to grip flat objects such as film. Specify the attachment shape and tip machining (shape left as punched, chamfered edges, ground edges, etc.).

Shape 1 (RS50)

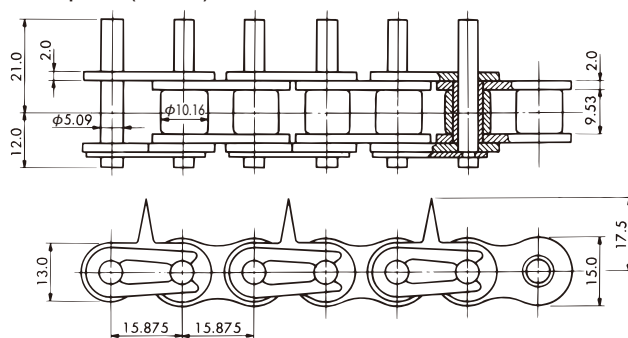

Shape 2 (RS50)

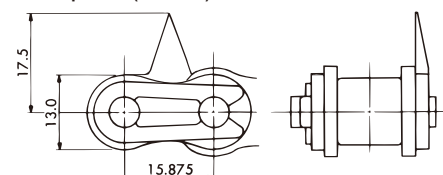

The tip of the attachment is sharp. Take care when handling.



Gripper Attachment (Attachment Types: KU, KUM)

Gripper attachment for gripping and conveying film, etc.

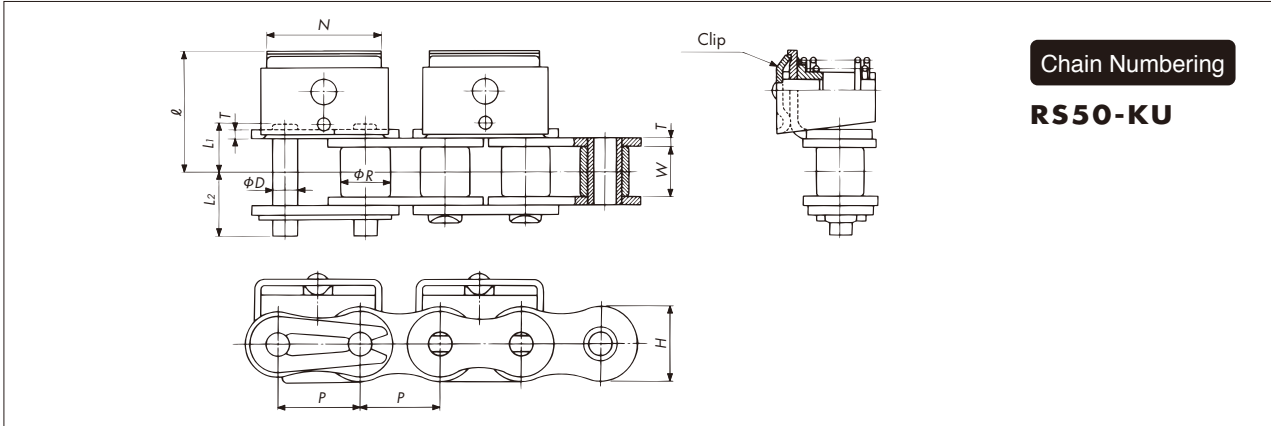

Chain Numbering
RS50-KU

Attachment Dimensions

Tsubaki Chain No.	Pitch P	Roller Dia R	Inner Link Inner Width W	Pin			Plate		Clip	
				Dia D	L1	L2	Width H	Thickness T	ℓ	N
RS08B-KU	12.70	8.51	7.75	4.45	8.53	10.05	11.8	1.5	20.15	18.0
RS50-KU	15.875	10.16	9.53	5.09	12.0	15.0	15.0	2.0	26.7	18.0

Note: Available in steel, nickel-plated steel, or stainless steel, Lambda NP.

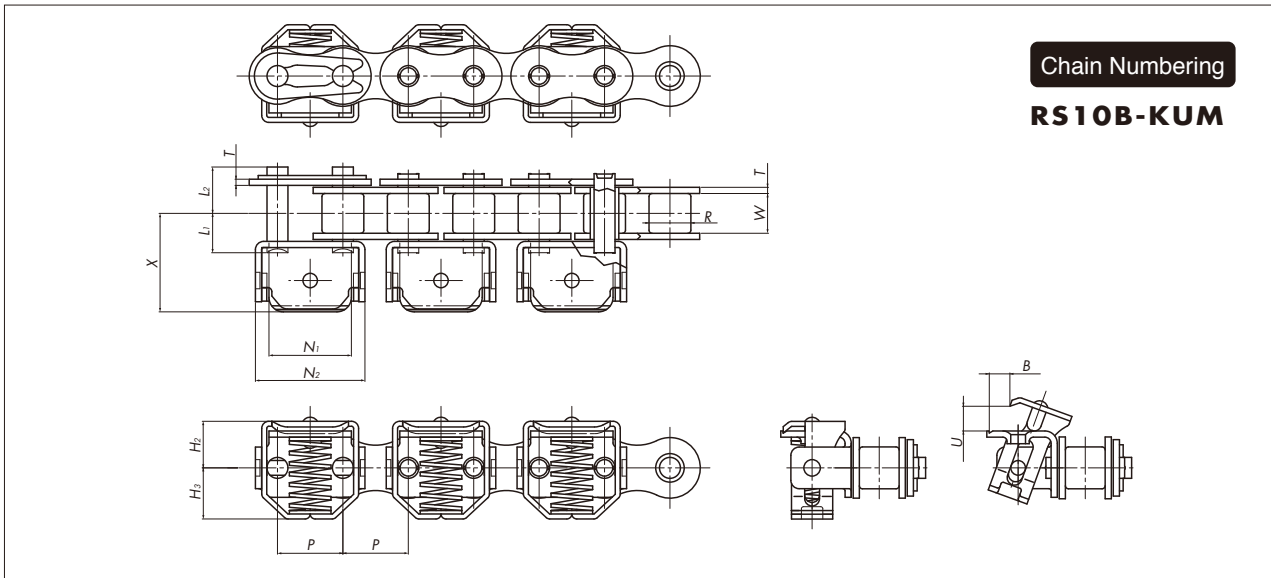

Chain Numbering
RS10B-KUM

Attachment Dimensions

Tsubaki Chain No.	Pitch P	Roller Dia R	Inner Link Inner Width W	Pin			Plate		X	Ni	N2	H2	H3	U	B	Spring Load N
				Dia D	L1	L2	Width H1	Thickness T								
RS08B-KUM	12.70	8.51	7.75	4.45	8.4	10.0	12.0	1.6	20.3	16.8	22.8	10.5	10.8	(4.2)	(3.7)	50
RS10B-KUM	15.875	10.16	9.65	5.08	9.55	11.25	14.7	1.5	23.9	20.0	26.6	11.3	12.4	(6.0)	(5.0)	70

Note: 1. Steel, nickel-plated steel, Lambda NP, and stainless steel types are available.
 2. Spring load values are for when the spring is closed.
 3. Lambda Chain specifications are also available. Contact a Tsubaki representative for more details.

Gripper Chain® Sprockets

Chain Size	No. of Teeth	Dimension PCD (mm)	φA (mm)	B (mm)	C (mm)
RS08B	17T	69.12	60.0	47.0	24.4
RS10B	14T	71.34	60.0	49.5	23.5
RS10B	19T	96.45	82.0	49.5	23.5

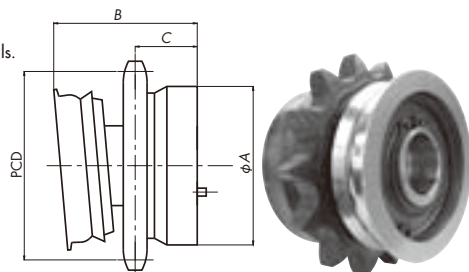

Design Stock

Design stock of reliable designs. Selecting from among these designs will improve overall design efficiency for your application.



Double Pitch

Magnetic Attachment (Attachment Type: MG)

A magnet mounted on the attachment holds conveyed objects. Can be used for inclined conveyance.

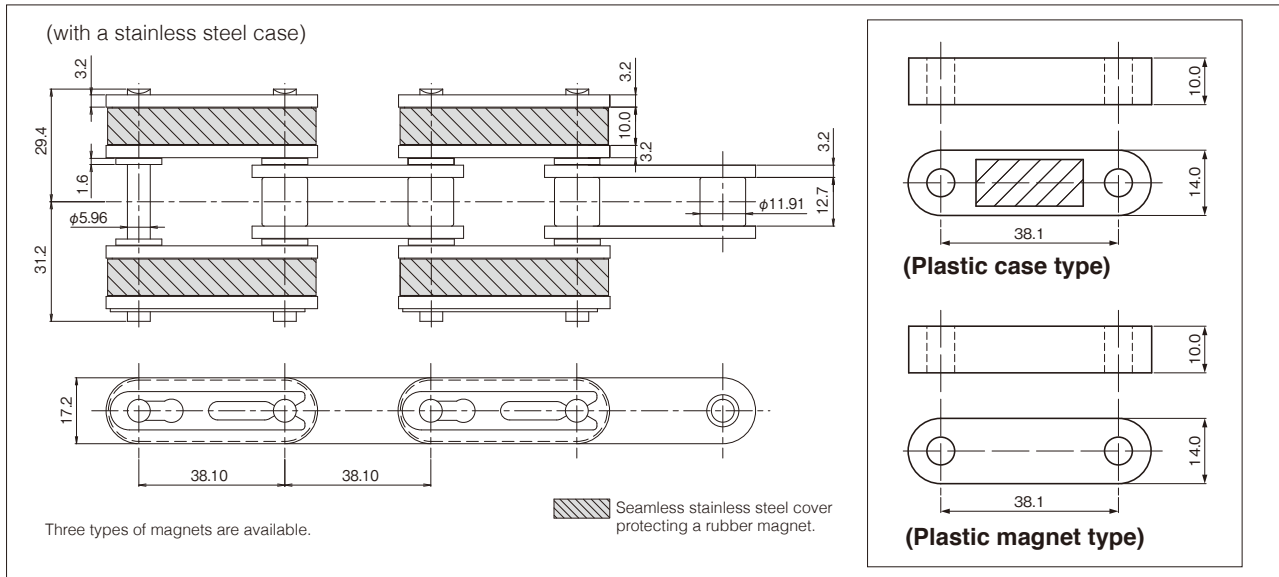

RS

Rubber Attachment (Attachment Type: RSG)

A layer of rubber is bonded to the attachment. The elasticity of the rubber allows objects to be conveyed between chains.

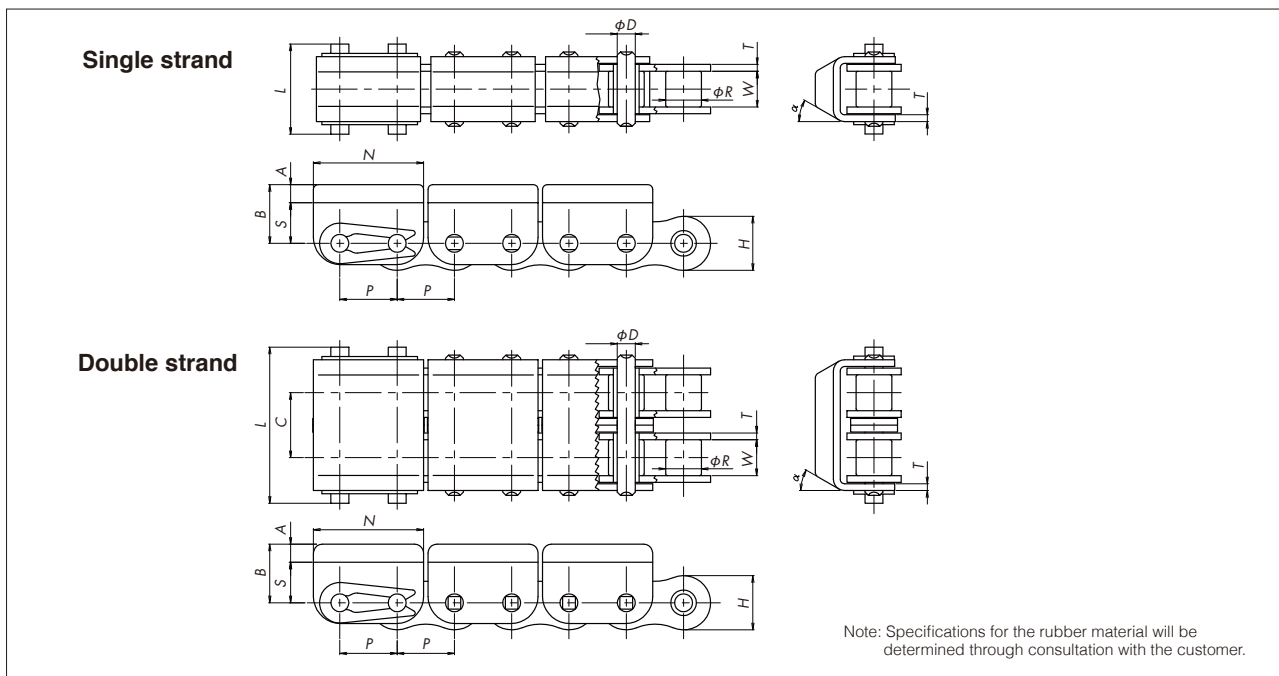

Attachment Dimensions

Tsubaki Chain No.	No. of Strands	Pitch P	Roller Dia ϕR	Width Between Inner Link Plates W	Transverse Pitch C	Pin		Plate		Attachment				
						Dia ϕD	Length L	Width H	Thickness T	N	S	A	B	α
RS40	1	12.70	7.92	7.95	—	3.97	20.0	12.0	1.5	24.4	9.0	4.0	13.0	30°
RS40-2	2	12.70	7.92	7.95	14.4	3.97	34.6	12.0	1.5	24.4	9.0	4.0	13.0	30°
RS40-3	3	12.70	7.92	7.95	14.4	3.97	48.8	12.0	1.5	24.4	9.0	6.0	15.0	0°
RS50-2	2	15.875	10.16	9.53	18.1	5.09	42.0	15.0	2.0	28.8	13.0	10.0	23.0	20°
RS60	1	19.05	11.91	12.7	—	5.96	29.5	18.1	2.4	34.6	13.0	10.0	23.0	0°
RS60-2	2	19.05	11.91	12.7	22.8	5.96	52.4	18.1	2.4	34.6	13.0	10.0	23.0	20°

*Dimension L is calculated as both ends of the chain having a connecting link.





Crescent Top Plate (Attachment Type: CL)

For horizontal circular conveyance.

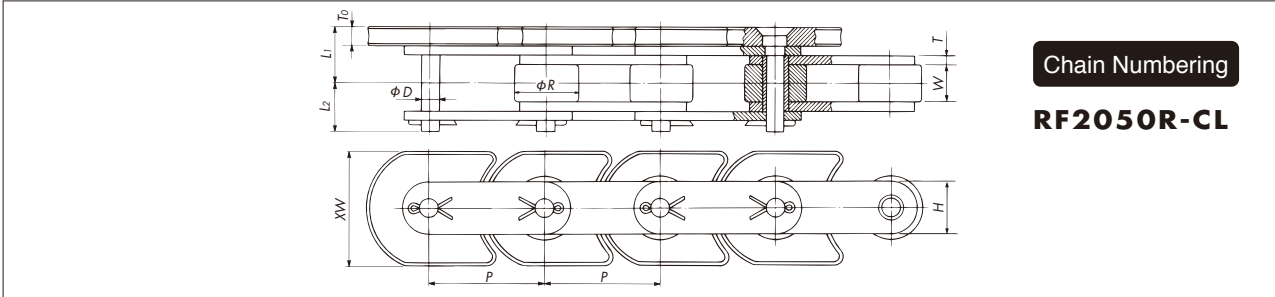

Chain Numbering
RF2050R-CL

Attachment Dimensions

Tsubaki Chain No.	Pitch P	Roller Dia R	Inner Link Inner Width W	Pin			Plate		Top Plate	
				Dia D	L1	L2	Width H	Thickness T	Width XW	Thickness To
RF2050R-CL	31.75	19.05	9.53	5.09	15.05	11.9	15.0	2.0	32	6.0
RF2060R-CL	38.10	22.23	12.70	5.96	19.5	16.95	17.2	3.2	38.1	6.35
RF2080R-CL	50.80	28.58	15.88	7.94	24.2	21.1	23.0	4.0	50	8.0
RF2100R-CL	63.50	39.69	19.05	9.54	25.9	24.3	28.6	4.8	63.5	6.35



Slat (Attachment Type: SLT [Riveted])

Slats are installed on tough RF Double Pitch Chains. Ideal for conveying relatively heavy material.

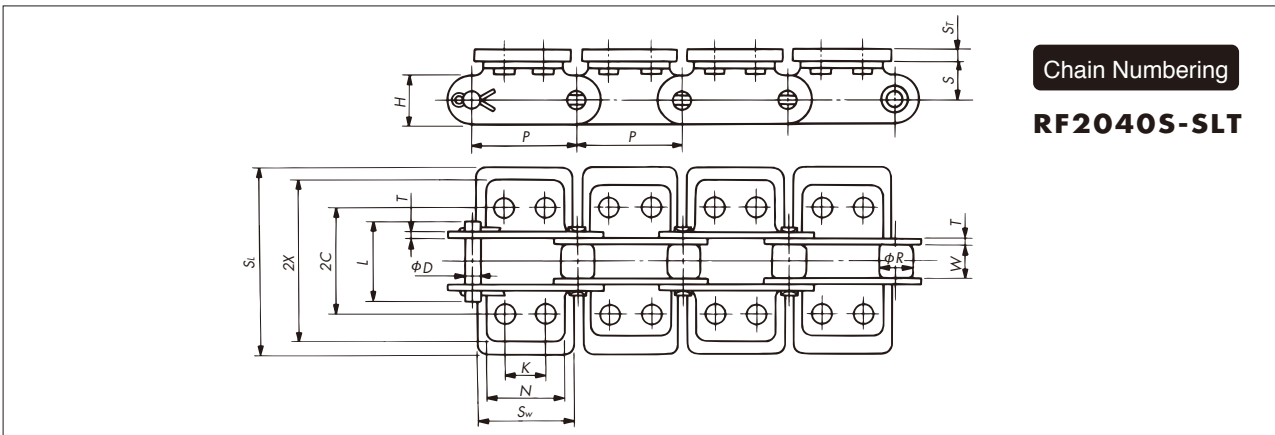

Chain Numbering
RF2040S-SLT

Attachment Dimensions

Tsubaki Chain No.	Pitch P	Inner Link Inner Width W	Roller Dia. R		Pin		Plate		
			S Roller	R Roller	L	Dia D	Width H	Thickness T	
RF2040S-SLT	RF2040R-SLT	25.40	7.95	7.92	15.88	19.3	3.97	12.0	1.5
RF2050S-SLT	RF2050R-SLT	31.75	9.53	10.16	19.05	23.8	5.09	15.0	2.0
RF2060S-SLT	RF2060R-SLT	38.10	12.70	11.91	22.23	33.9	5.96	17.2	3.2
RF2080S-SLT	RF2080R-SLT	50.80	15.88	15.88	28.58	41.9	7.94	23.0	4.0

Tsubaki Chain No.	2C	2X	K	N	S	Sr	Sl	Sw	
RF2040S-SLT	RF2040R-SLT	25.4	38.6	9.5	19.1	9.1	3.2	50.8	24.0
RF2050S-SLT	RF2050R-SLT	31.8	48.4	11.9	23.8	11.1	4.0	63.5	30.0
RF2060S-SLT	RF2060R-SLT	42.9	63.0	14.3	28.6	14.7	4.8	76.2	36.0
RF2080S-SLT	RF2080R-SLT	55.6	81.4	19.1	38.1	19.1	5.6	101.6	48.0



Design Stock

Design stock of reliable designs. Selecting from among these designs will improve overall design efficiency for your application.



Double Pitch

Slat (Attachment Type: SLW [Welded])

Slats are installed on RF Double Pitch Chains. Ideal for conveying relatively heavy material.

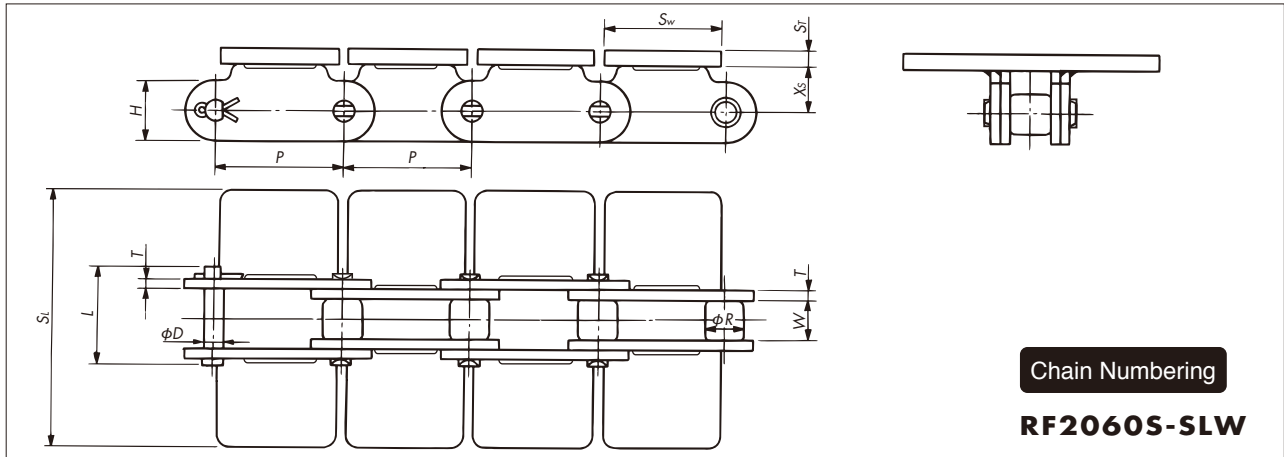

Chain Numbering

RF2060S-SLW

Attachment Dimensions

Tsubaki Chain No.		Pitch P	Inner Link Inner Width W	Roller Dia.R		Pin		Plate		ST	SL	SW	XS
				S Roller	R Roller	L	Dia D	Width H	Thickness T				
RF2060S-SLW	RF2060R-SLW	38.10	12.70	11.91	22.23	31.5	5.96	17.2	3.2	3.2	76.2	36.0	14.7
RF2080S-SLW	RF2080R-SLW	50.80	15.88	15.88	28.58	39.9	7.94	23.0	4.0	4.5	101.6	48.0	19.1



RS

RS Slat (Attachment Type: SLT [Riveted])

Small pitch RS chains mean short attachment spacing, making them perfect for conveying small items. Small pitches also mean smooth operation.

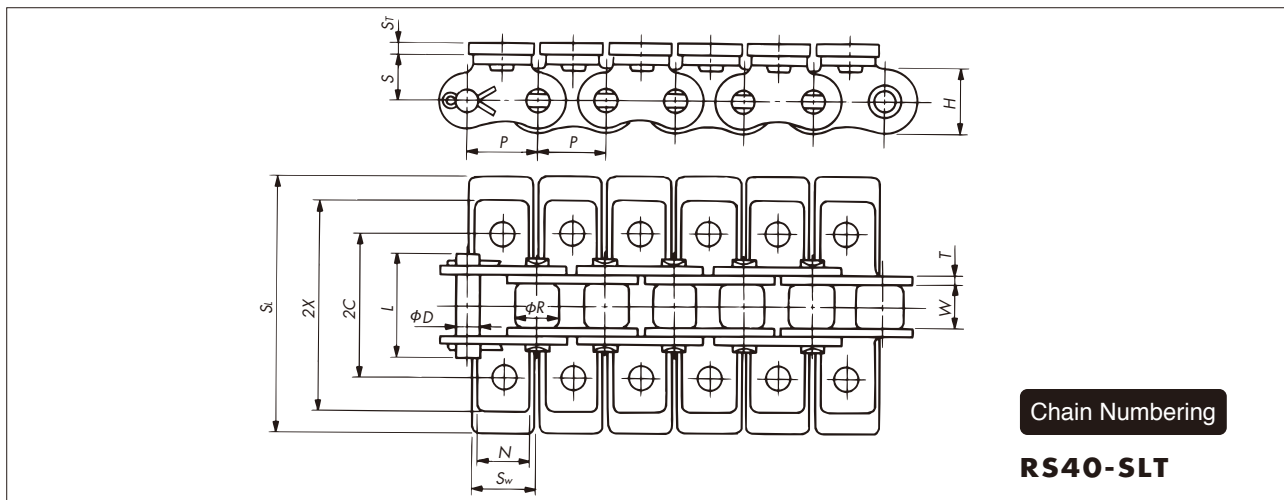

Chain Numbering

RS40-SLT

Attachment Dimensions

Tsubaki Chain No.	Pitch P	Inner Link Inner Width W	Roller Dia R	Pin		Plate		2C	2X	N	S	Sr	Sl	Sw
				Dia D	L	Width H	Thickness T							
RS40-SLT	12.70	7.95	7.92	3.97	19.3	12.0	1.5	25.4	35.6	9.5	8.0	3.2	50.8	12.0
RS50-SLT	15.875	19.53	10.16	5.09	23.8	15.0	2.0	31.8	46.8	12.7	10.3	3.2	63.5	15.0
RS60-SLT	19.05	12.70	11.91	5.96	30.5	18.1	2.4	38.1	56.4	15.9	11.9	4.0	76.2	18.0
RS80-SLT	25.40	15.88	15.88	7.94	38.5	24.1	3.2	50.8	73.2	19.1	15.9	4.8	101.6	24.0

Double Pitch R S **Pusher Attachment (Attachment Type: SD)**

Ideal for directly pushing conveyed items.

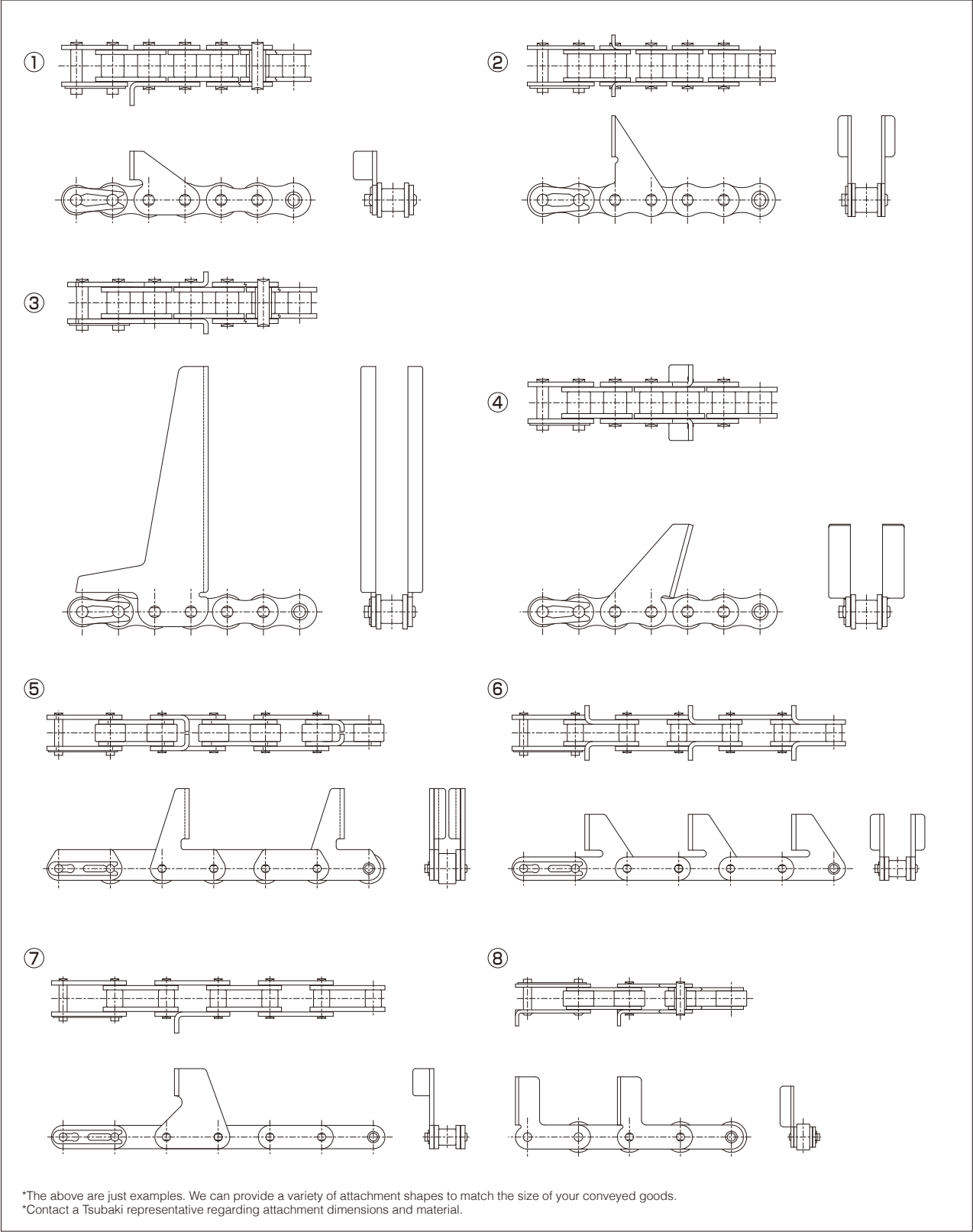

Design Stock

Design stock of reliable designs. Selecting from among these designs will improve overall design efficiency for your application.



Double Pitch

Top Plate with Bonded Rubber Pad (Attachment Type: PSG)

Rubber pads have been bonded onto the top plates to prevent scratching items.

Technical drawing showing front and side views of the top plate with bonded rubber pad. Dimensions include: 14.8, 13.0, 2.4, $\phi 5.95$, 36.5, 1.6, 12.7, 2.4, XW, 18.0, 38.10, 38.10, 10.4, A, B.

Chain Numbering

TS826-NP-PSG
(826=82.6mm)

Attachment Dimensions (mm)

Tsubaki Chain No.	Top Plate Width XW	Rubber Pad Thickness A	B	R
TS826-NP-PSG	82.6	5	18.6	1
TS1100-NP-PSG	110.0	3	16.6	1

Note: 1. Uses nitrile rubber.
2. Stainless steel specifications also available.
3. Made-to-order item.



Double Pitch

Tempered Top Plate (Attachment Type: HTP)

The carbon steel top plate has been hardened and tempered to prevent scratching.

Technical drawing showing front and side views of the tempered top plate. Dimensions include: 41.5, 14.8, 13.0, 2.4, $\phi 5.95$, 36.5, 1.6, 12.7, 2.4, XW, 18.0, 38.10, 38.10, 10.4, 3.2, 13.6.

Chain Numbering

TS826-HTP
(826=82.6mm)

Attachment Dimensions (mm)

Product Code	Tsubaki Chain No.	Top Plate Width XW
C121115	TS550-HTP	55.0
C121116	TS635-HTP	63.5
C121117	TS762-HTP	76.2
C121118	TS826-HTP	82.6
C121119	TS950-HTP	95.0
C121120	TS1016-HTP	101.6

Note: 1. Top plate hardened to roughly HRC40 (same as base chain).
2. Top plates are riveted to the attachments.
3. Made-to-order item.



Double Pitch

Bent End Top Plate (Attachment Type: SM)

Enables smooth lateral transfer of conveyed items.

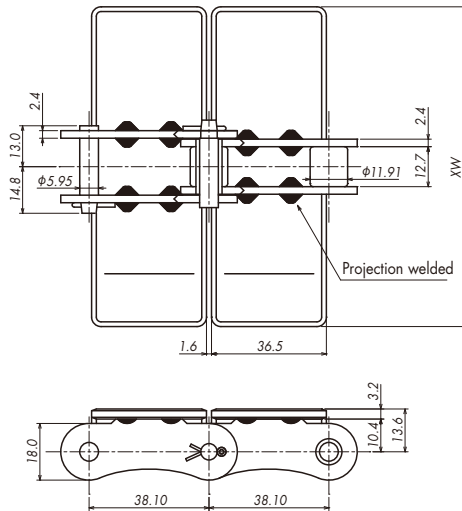

• Plate height (H) is 19.4mm when the base chain is stainless steel.

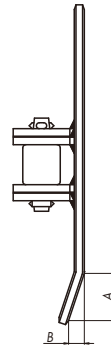

Chain Numbering

TS826-SM
(826=82.6mm)

Attachment Dimensions (mm)

Tsubaki Chain No.	Top Plate Width XW	A	B
TS826-SM	82.6	12	5
TS1106-SM	101.6	15	5
TS1270-SM	127.0	15	5
TS1524-SM	152.4	19	7
TS1905-SM	190.5	20	8

Note: 1. Also available in TT Series
 2. Made-to-order item.



Double Pitch

Inclined Top Plates (30°) (Attachment Type: CTP)

The space between the upper faces of the slats are small, preventing conveyed items from getting caught.

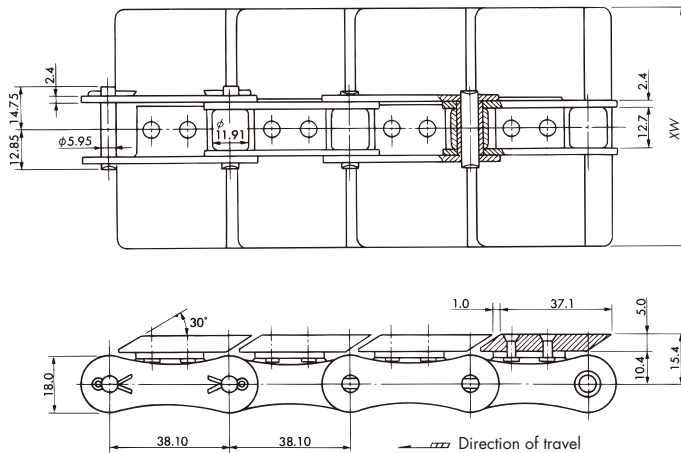

• TS826-CTP also available.

Chain Numbering

TS635-CTP
(635=63.5mm)

Attachment Dimensions (mm)

Product Code	Tsubaki Chain No.	Top Plate Width XW
C121121	TS635-CTP	63.5
C121122	TS762-CTP	76.2

Note: 1. Features a large backbend radius. Be aware of your layout when replacing standard TS Series products with this chain.
 2. Made-to-order item.

Special Attachments

Examples of special attachments

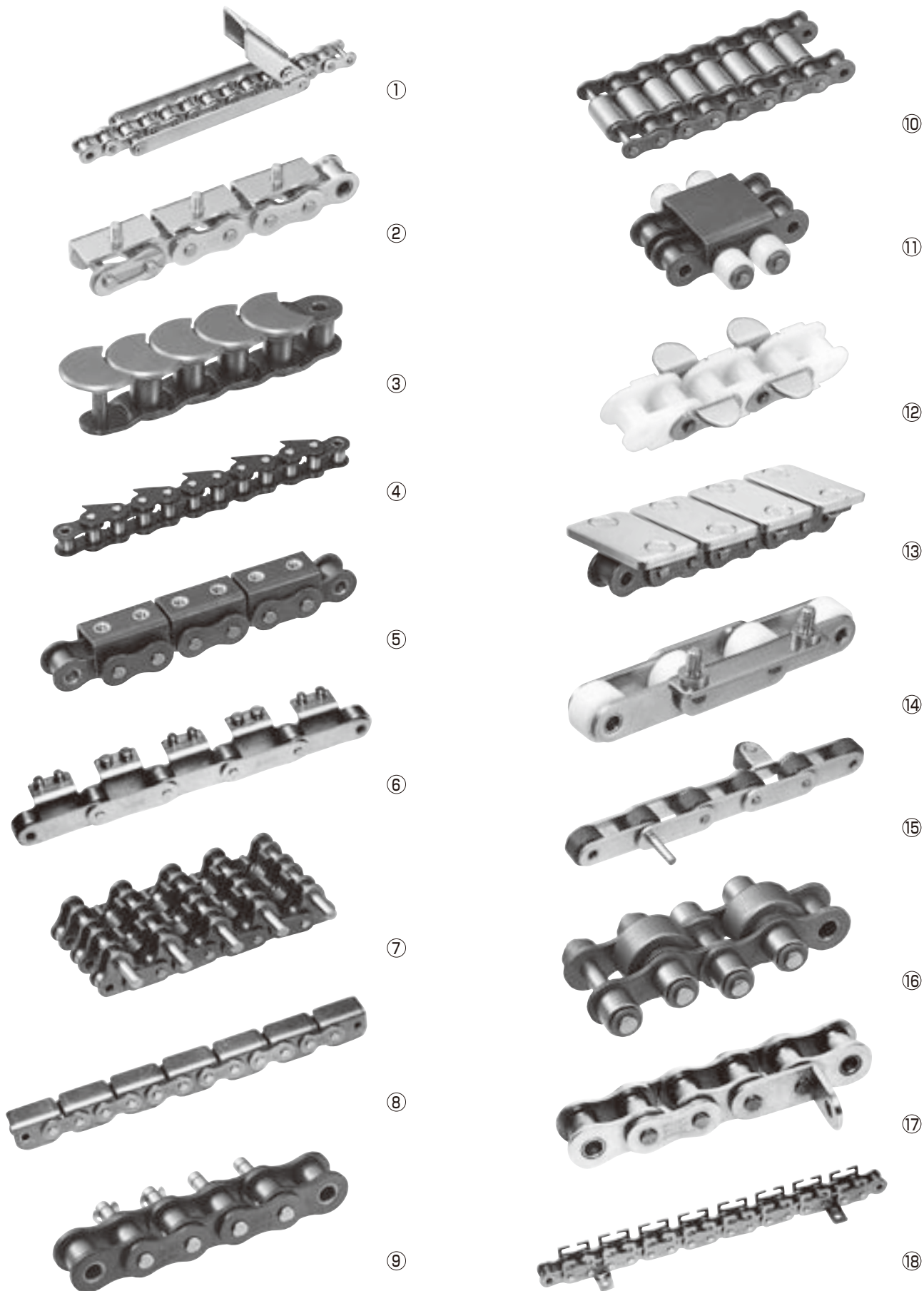



19



20



21

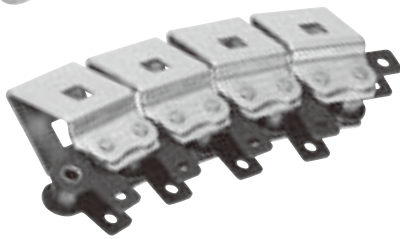

22

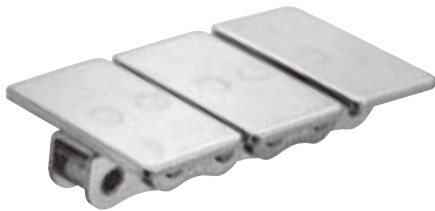

23



24



25



26

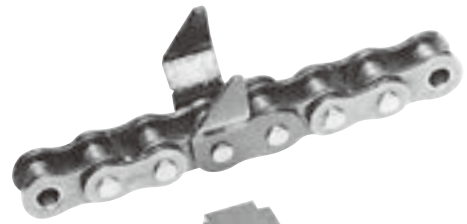

27

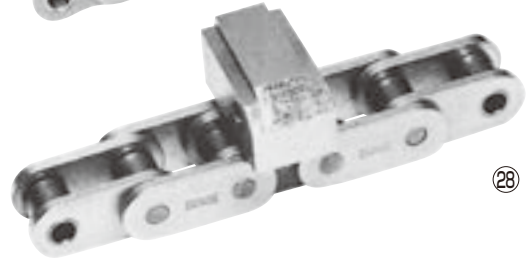

28



29



30

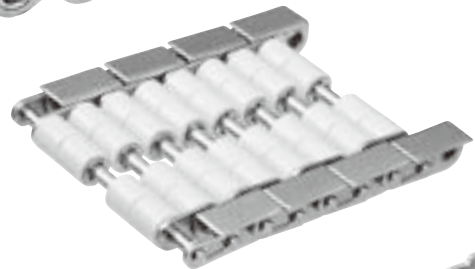

31

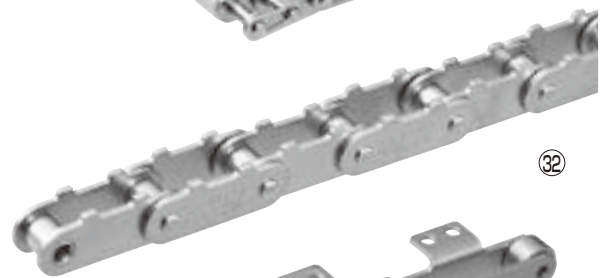

32

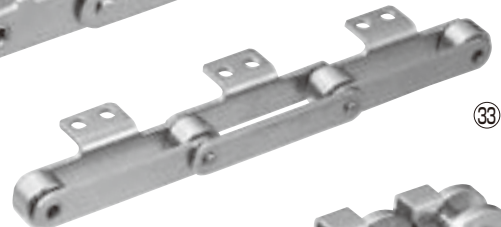

33

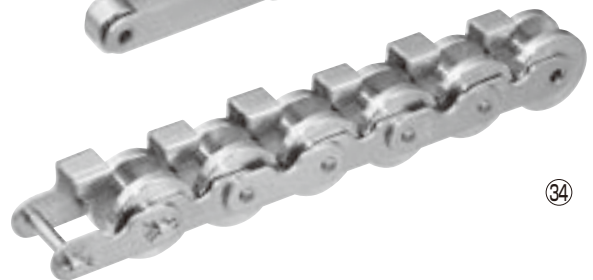

34

Special Attachments



35

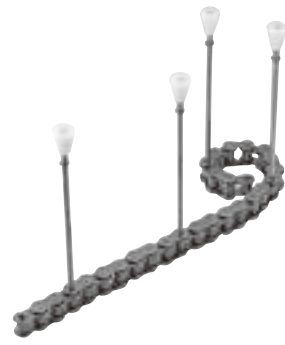

41

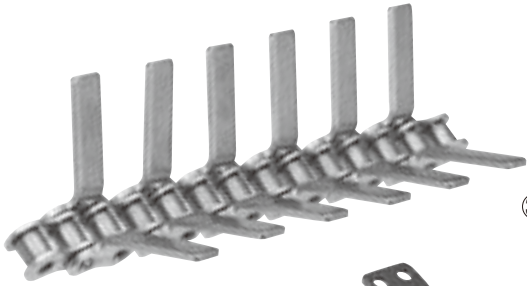

36



42

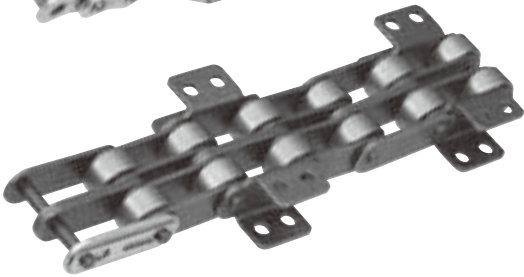

37

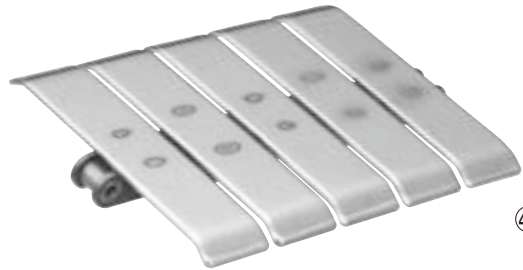

43



38

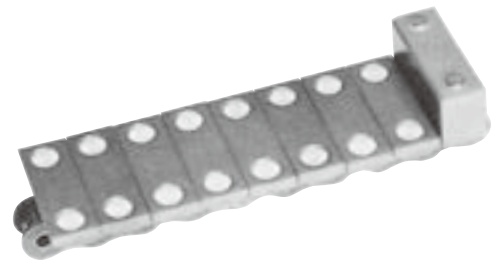

44



39

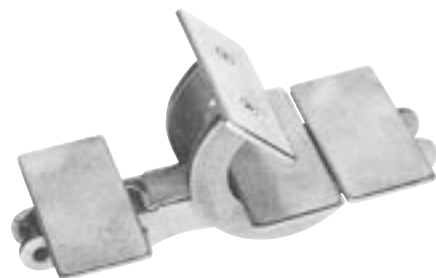

45

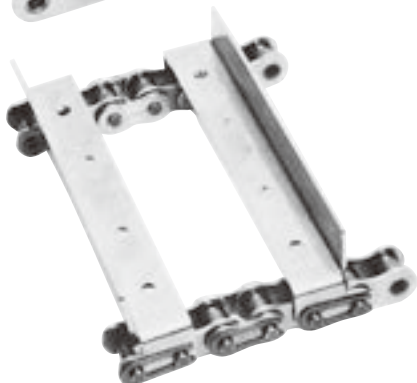

40

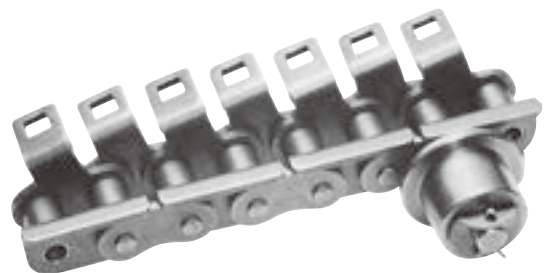

46

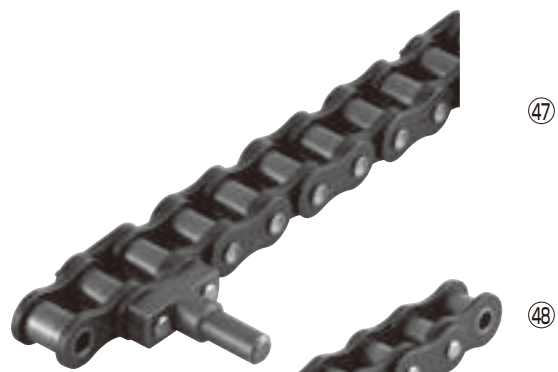

47



48



49

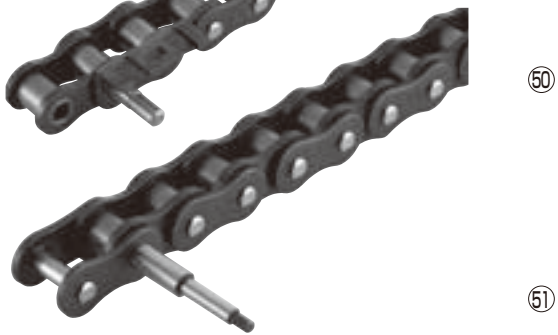

50

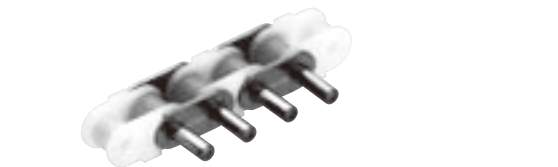

51



52

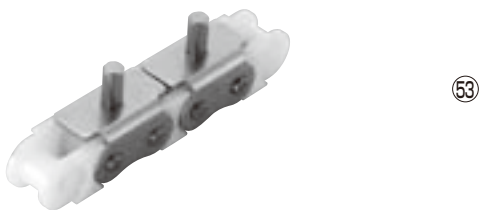

53



54

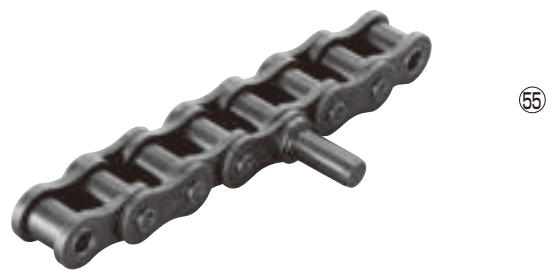

55

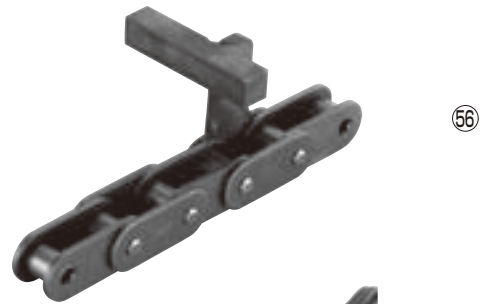

56

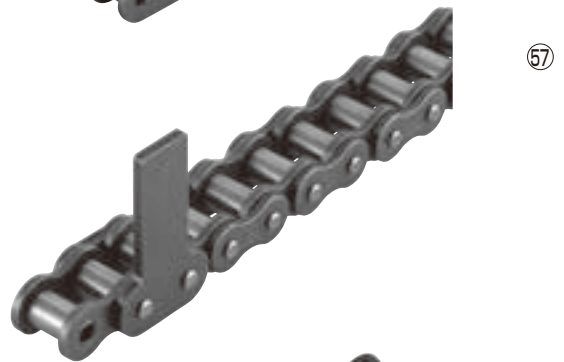

57



58

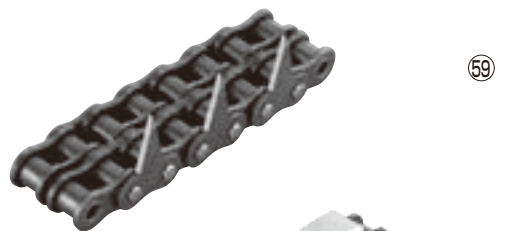

59

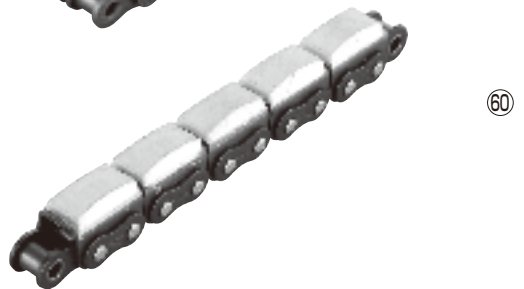

60



61

RS80

A 1 / K 1

W A 2 / W K 2

E P

S A 1 / S K 1

W S A 2 / W S K 2

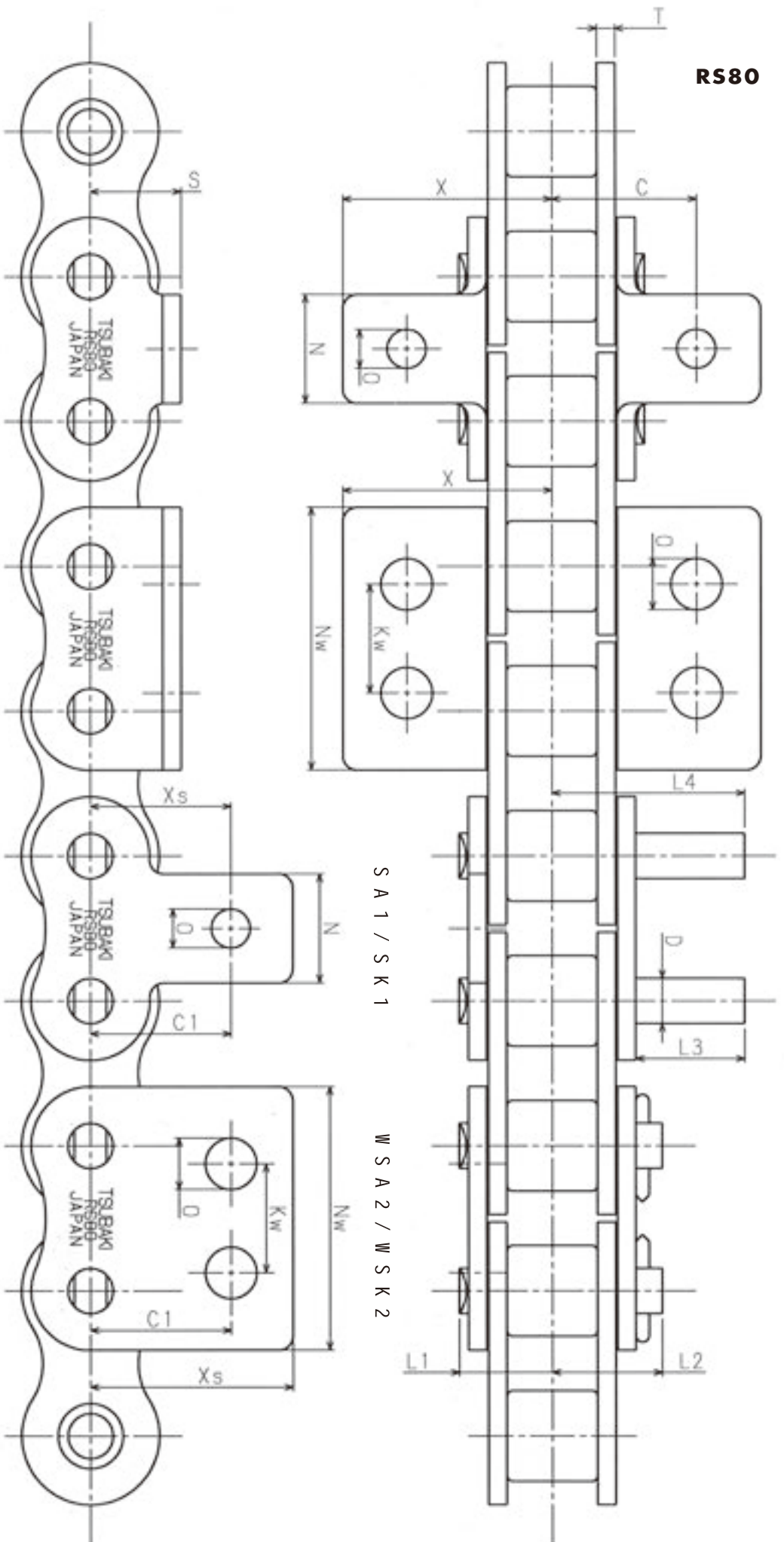

■ Attachment Dimensions

Tsubaki Chain No.	Pitch P	Roller Dia R	Inner Link Inner Width W	Plate			Pin			Attachment													
				Thickness T	Width H	Width h	Dia D	L1	L2	C	C1	N	O	S	T	X	Xs	D	L3	L4	NW (if outer link)	NW (if inner link)	KW
RS40	12.70	7.92	7.95	1.5	12.0	10.4	3.97	8.25	9.95	12.7	12.7	9.5	3.6(4.5)	8.0	1.5	17.8	17.4	3.97	9.5	16.75	23.0	24.7	9.5
RS50	15.875	10.16	9.53	2.0	15.0	13.0	5.09	10.3	12.0	15.9	15.9	12.7	5.2(5.5)	10.3	2.0	23.4	23.05	5.09	11.9	21.0	28.8	30.9	11.9
RS60	19.05	11.91	12.70	2.4	18.1	15.6	5.96	12.85	14.75	19.05	18.3	15.9	5.2(6.6)	11.9	2.4	28.2	26.85	5.96	14.3	25.75	34.6	37.2	14.3
RS80	25.40	15.88	15.88	3.2	24.1	20.8	7.94	16.25	19.25	25.4	24.6	19.1	6.8(9.0)	15.9	3.2	36.6	35.45	7.94	19.1	33.85	46.1	49.5	19.1

*For WA, WK, WSA, and WSK attachments, dimension O is in the parentheses.

(mm)

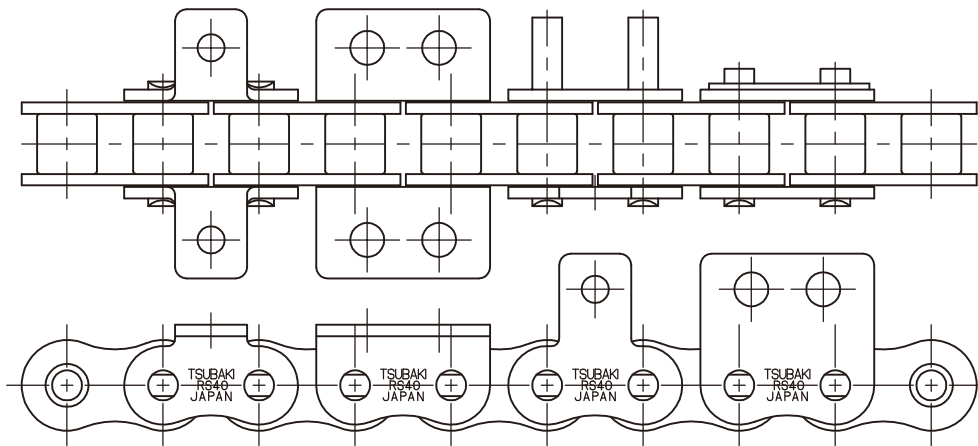

RS40

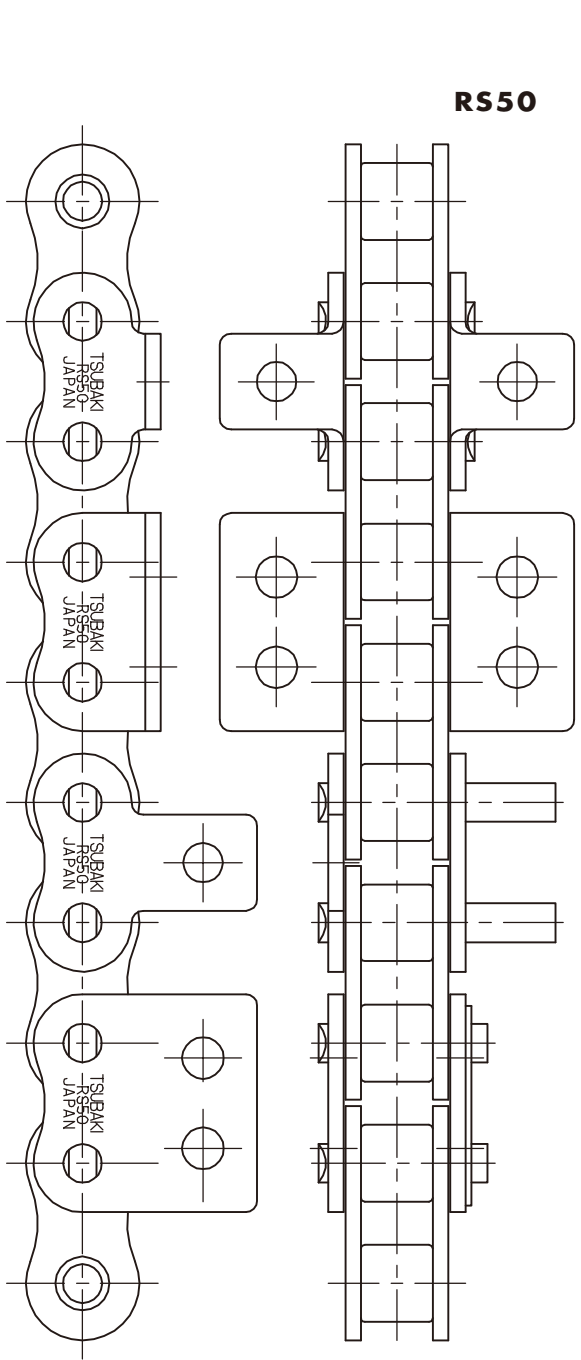

RS50

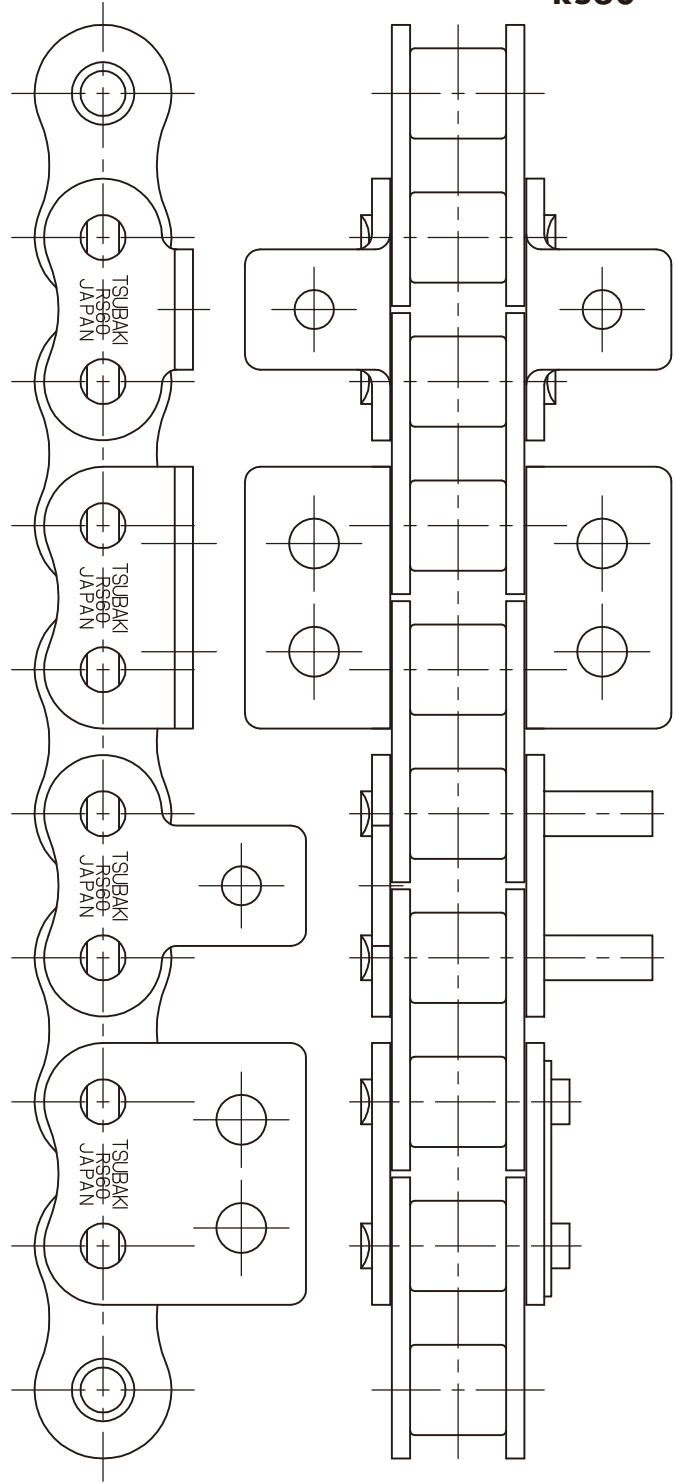

RS60

Small Size Conveyor Chain Inquiry Sheet (for Integrated Attachment Chain)

When submitting your inquiry, please be sure to circle one of the following anticipated effects from using Integrated Attachment Chain.

Anticipated effects of using integrated attachment chain	Improved workability Longer chain life Less time spent ordering	Lower costs/less inventory Fewer workers Prevent foreign material from getting into product	More efficient production lines Better safety Shorter delivery	Less time spent on design Other:
Machine used			Chain speed*	m/min
Type	New equipment Replacement or remodeling	Existing equipment	Min. tensile strength	kN(kgf)
Planned chain replacement (date)			Chain pitch	mm
Operating temperature	Room temp.	°C	Attachment type* EP/A/K/SA/SK/WA/ WSA/Special	att. every links
Corrosiveness			Conveyance method*	Pushed by dogs, direct conveyance, horizontal conveyance, inclined conveyance
Abrasiveness			Other details	
Conveyed item(s) (name)				
Conveyed item(s) temp.*	Room temp.	°C	Operating time	hrs/day
Conveyed item(s) dimensions (shape)*			Operating method	Continuous intermittent Reverse (yes/no)
Conveyed item(s) weight	Max.	kg/each	Lubricated operation?	Yes / no
Conveyance weight	Max.	ton/hour (bulk)	Motor used	AC/DC kW x rpm x motors
		kg/each (countable)	Sprocket no. of teeth	NT (PCD mm)
No. of items (weight)*	Max		Sprocket bore dia.	ϕ H8/H7
Conveyor length*		m	Hub	Type () ϕ x L
Lifting height*		m	Keyway	Not required () JIS/b x t parallel/driving
No. of chain strands*		strands (spacing: m)	Sprocket tooth finishing	Machine cut Induction hardening

*Indicated required information.

Jigs, slats, and other items to be mounted to the attachments.

① Jig shape, material, weight, and other information. (Attach any jig drawings if possible.)
② Jig mounting method, points, etc.
③ Jig unit cost, mounting cost, mounting time, procurement method, etc.

Brief description of machine used and chain: Configuration of conveyor, method for loading and unloading of items to be conveyed, rail configuration, method of receiving on return side, drive sprocket position, direction of travel, chain guide, points of interference with the equipment, and other remarks.

Company name: _____

Your name: _____

Tel/Fax _____

For Your Safety When Using the Chain

For Your Safety When Using the Chain



Warning To avoid danger, observe the following rules.

- Do not use chain or chain accessories for any purpose other than their originally intended use.
- Never perform additional work on chain.
 - Do not anneal any chain parts.
 - Do not clean chain with acids or alkalis. These may cause cracking.
 - Never attempt to electroplate chain or chain parts. This may cause hydrogen embrittlement.
 - Do not weld chain. Heating effects will cause weakening and cracking.
 - When a torch is used to heat or cut chain, remove the links on each side and do not reuse them.
- When replacing a worn or damaged part, do not replace just the worn or damaged part. Replace all parts with new parts.
- If a material that causes hydrogen embrittlement (acid, strong alkali, battery fluid, etc.) comes in contact with the chain, immediately stop using the chain and replace it with new chain.
- When using chain in a lifting device, set up a safety barrier and do not allow anyone to go under the equipment.
- Always install safety equipment (safety covers, etc.) on chain and sprockets.
- Strictly observe the general guidelines listed in Section 1, Chapter 1, 2nd Edition of the Japanese Occupational Safety and Health Regulations as well as rules and regulations concerning occupational safety and health in your region/country.
- When installing, removing, inspecting, maintaining and oiling chain,
 - Perform the work as instructed in the manual, catalog or other documentation that was provided with the product.
 - Before starting work, turn off the power switch and take measures to prevent it from being turned on accidentally.
 - Secure the chain and parts to prevent them from moving freely.
 - Use a press tool or other special tools to separate or connect chain, and follow the correct procedures.
 - Remove and insert pins and rivets in the correct direction.
 - Wear clothing and protective gear (safety glasses, gloves, safety shoes, etc.) that are appropriate for the work.
 - Only experienced personnel should perform chain replacement.



Caution To prevent accidents, observe the following rules.

- Understand the structure and specifications of the chain that you are handling.
- Before installing chain, inspect it to make sure no damage occurred during delivery.
- Inspect and maintain chain and sprockets at regular intervals.
- Chain strength varies by manufacturer. Only Tsubaki products should be used when chain is selected using Tsubaki catalogs.
- Minimum tensile strength refers to the failure point when the corresponding load is applied to the chain once and does not refer to the allowable operational load.

Warranty

1. LIMITED WARRANTY

Products manufactured by Seller: (a) conform to the design and specifications, if any, expressly agreed to in writing by Seller; and (b) are free of defects in workmanship and materials at the time of shipment. The warranties set forth in the preceding sentence are exclusive of all other warranties, express or implied, and extend only to Buyer and to no other person. ALL WARRANTIES OF MERCHANTABILITY OR FITNESS FOR A PARTICULAR PURPOSE ARE HEREBY EXCLUDED.

2. NON-RELIANCE

Buyer is not relying upon any advice, representations or warranties (except the warranties expressly set forth above) of Seller, or upon Seller's skill or judgment regarding the Seller's products.

Buyer is solely responsible for the design and specifications of the products, including without limitation, the determination of suitability for Buyer's application of the products.

3. CLAIMS

- (a) Any claim relating to quantity or type shall be made to Seller in writing within 7 days after receipt of the products; any such claim made thereafter shall be barred.
- (b) Any claim under the above-stated Limited Warranty shall be made to Seller in writing within three (3) months after receipt of the products; any such claim made thereafter shall be barred.
- (c) Seller's liability for breach of warranty or otherwise is limited to repair or replacement, at Seller's option, of non-conforming or defective products. Buyer waives all other remedies, including, but not limited to, all rights to

consequential, special or incidental damages, including, but not limited to, damages resulting from personal injury, death or damage to or loss of use of property.

- (d) Repair, alteration, neglect or misuse of the products shall void all applicable warranties.

4. INDEMNIFICATION

Buyer will indemnify, defend and hold Seller harmless from all loss, liability, damage and expense, including attorneys' fees, arising out of any claim (a) for infringement of any patent, trademark, copyright, misappropriation of trade secrets, unfair competition or similar charge by any products supplied by Seller in accordance with the design or specifications furnished by Buyer, or (b) arising out of or connected with the products or any items into which the products are incorporated, including, but not limited to, any claim for product liability (whether or not based on negligence or strict liability of Seller), breach of warranty, breach of contract or otherwise.

5. ENTIRE AGREEMENT

These terms and conditions constitute the entire agreement between Buyer and Seller and supersede any inconsistent terms and conditions, whether contained in Buyer's purchase order or otherwise, and whether made heretofore or hereafter.

No statement or writing subsequent to the date hereof which purports to modify or add to the terms and conditions hereof shall be binding unless consented to in writing, which makes specific reference hereto, and which has been signed by the party against which enforcement thereof is sought. Seller reserves the right to change these terms and conditions without prior notice.



TSUBAKIMOTO CHAIN CO.

Headquarters

Nakanoshima Mitsui Building
3-3-3 Nakanoshima, Kita-ku
Osaka 530-0005, Japan
Phone : +81-6-6441-0011
Facsimile : +81-6-6441-0489
Internet :
<http://tsubakimoto.com/>

Chain Division

Chain Sales Department
1-3 Kannabidai 1-chome
Kyotanabe, Kyoto 610-0380, Japan
Phone : +81-774-64-5100
Facsimile : +81-774-64-5212

For further information please
contact the Chain Division.

Global Associated Partners:

NORTH and SOUTH AMERICA

U.S. TSUBAKI, INC.

301 E. Marquardt Drive
Wheeling, IL 60090-6497
U.S.A.
Phone : +1-847-459-9500
Facsimile : +1-847-459-9515

TSUBAKI BRASIL EQUIPAMENTOS INDUSTRIAIS LTDA.

R. Pamplona, 1018 - CJ. 73/74
Js. Paulista - 01405-001
São Paulo - S.P. Brazil
Phone : +55-11-3253-5656
Facsimile : +55-11-3253-3384

TSUBAKI OF CANADA LIMITED

1630 Drew Road
Mississauga, Ontario, L5S 1J6
Canada
Phone : +1-905-676-0400
Facsimile : +1-905-676-0904

EUROPE

TSUBAKIMOTO EUROPE B.V.

Aventurijn 1200, 3316 LB Dordrecht
The Netherlands
Phone : +31-78-6204000
Facsimile : +31-78-6204001

TSUBAKIMOTO U.K. LTD.

Osier Drive, Sherwood Park
Annesley, Nottingham
NG15 0DX U.K.
Phone : +44-1623-688-700
Facsimile : +44-1623-688-789

TSUBAKI DEUTSCHLAND GMBH

ASTO Park Oberpfaffenhofen
Friedrichshafener Straße 1, D-82205
Gilching, Germany
Phone : +49-8105-7307100
Facsimile : +49-8105-7307101

TSUBAKI KABELSCHLEPP GMBH

Daimlerstraße 2, D-57482
Wenden-Gerlingen Germany
Phone : +49-2762-4003-0
Facsimile : +49-2762-4003-220

ASIA and OCEANIA

TAIWAN TSUBAKIMOTO CO.

No. 33, Lane 17, Zihciang North Road
Gueishan Township, Taoyuan County
Taiwan
Phone : +886-33-293827/8/9
Facsimile : +886-33-293065

TSUBAKIMOTO SINGAPORE PTE. LTD.

25 Gul Lane
Jurong
Singapore 629419
Phone : +65-6861-0422/3/4
Facsimile : +65-6861-7035

TSUBAKIMOTO CHAIN (SHANGHAI) CO., LTD.

Room 601, Urban City Centre, 45 Nanchang
Road, Huangpu District, Shanghai 200020
People's Republic of China
Phone : +86-021-5396-6651/6652
Facsimile : +86-021-5396-6628

TSUBAKI INDIA POWER TRANSMISSION PTE. LTD.

Chandrika Chambers No.4, 3rd Floor
Anthony Street, Royapettah, Chennai
Tamil Nadu 600014 India
Phone : +91-44-4231-5251
Facsimile : +91-44-4231-5253

PT. TSUBAKI INDONESIA TRADING

Wisma 46 - Kota BNI, 24th Floor
Suite 24.15, Jl. Jend. Sudirman Kav. 1
Jakarta 10220, Indonesia
Phone : +62-21-571-4230/31
Facsimile : +62-21-571-4232

TSUBAKI AUSTRALIA PTY. LIMITED

Unit E, 95-101 Silverwater Road
Silverwater, N.S.W. 2128
Australia
Phone : +61-2-9704-2500
Facsimile : +61-2-9704-2550

TSUBAKIMOTO (THAILAND) CO., LTD.

388 Exchange Tower, 19th Floor Unit 1902
Sukhumvit Road, Klongtoey
Bangkok 10110, Thailand
Phone : +66-02-262-0667/9
Facsimile : +66-02-262-0670

TSUBAKIMOTO KOREA CO., LTD.

1004, 1005 East Wing, Hanshin
Intervalley 24. 322, Teheran-ro
Gangnam-gu, Seoul
Republic of Korea
Phone : +82-02-2183-0311
Facsimile : +82-02-2183-0314

TSUBAKI AUSTRALIA PTY LIMITED - NEW ZEALAND BRANCH

2 Kalmia Street
Ellerslie, Auckland 1051
New Zealand
Phone : +64-9-914-1841
Facsimile :

TSUBAKIMOTO SINGAPORE PTE. LTD. VIETNAM REPRESENTATIVE OFFICE

H&H Building 8F, 209 Hoàng Văn Thụ
Phủ Nhuận District
Hồ Chí Minh City, Vietnam
Phone : +84-8-3999-0131/2
Facsimile : +84-8-3999-0130

Distributed by: